

The Embedded I/O Company



TPMC866-10R/-11R

8 Channel Serial Interface

Version 1.1

User Manual

Issue 1.1.2

March 2021

TEWS TECHNOLOGIES GmbH

Am Bahnhof 7 25469 Halstenbek, Germany

Phone: +49 (0) 4101 4058 0 Fax: +49 (0) 4101 4058 19

e-mail: info@tews.com www.tews.com

TPMC866-10R

8 channel RS232 serial interface PMC with front I/O and P14 I/O

TPMC866-11R

8 channel RS422 serial interface PMC with front I/O and P14 I/O

TPMC866-10R-ET

8 channel RS232 serial interface PMC with front I/O and P14 I/O, extended temperature range

TPMC866-11R-ET

8 channel RS422 serial interface PMC with front I/O and P14 I/O, extended temperature range

This document contains information, which is proprietary to TEWS TECHNOLOGIES GmbH. Any reproduction without written permission is forbidden.

TEWS TECHNOLOGIES GmbH has made any effort to ensure that this manual is accurate and complete. However TEWS TECHNOLOGIES GmbH reserves the right to change the product described in this document at any time without notice.

TEWS TECHNOLOGIES GmbH is not liable for any damage arising out of the application or use of the device described herein.

Style Conventions

Hexadecimal characters are specified with prefix 0x, i.e. 0x029E (that means hexadecimal value 029E).

For signals on hardware products, an 'Active Low' is represented by the signal name with # following, i.e. IP_RESET#.

Access terms are described as:

W	Write Only
R	Read Only
R/W	Read/Write
R/C	Read/Clear
R/S	Read/Set

©2001-2021 by TEWS TECHNOLOGIES GmbH

All trademarks mentioned are property of their respective owners.

Issue	Description	Date
1.0	First Issue	March 1998
1.1	Addition PCI Target Chip and reduced variety	May 1999
1.2	General Revision	April 2003
1.3	Baud Rate Programming Note Update	December 2003
1.4	Added Module Versions TPMC866-xx-ET	May 2004
1.5	New address TEWS LLC	September 2006
1.0.6	New notation for User Manual issue and Engineering Documentation, Corrected RxD signal names in pin assignment table	May 2012
1.1.0	Document Update caused by new Hardware Version	April 2013
1.1.1	General Revision	August 2014
1.1.2	Discarded RS485 Reference in Block Diagram	March 2021

Table of Contents

1	PRODUCT DESCRIPTION	6
2	TECHNICAL SPECIFICATION.....	7
3	LOCAL SPACE ADDRESSING.....	8
	3.1 PCI9030 Local Space Configuration.....	8
	3.2 Local Register Space 1	8
	3.2.1 Serial Channel Register Set.....	9
	3.2.1.1 Channel Register Set 1	9
	3.2.1.2 Channel Register Set 2.....	10
	3.2.2 Other Registers	11
	3.2.2.1 FIFO Ready 1 Register Channel 0-3	11
	3.2.2.2 FIFO Ready 2 Register Channel 4-7	12
	3.2.2.3 Interrupt Status Register	13
4	PCI9030 TARGET CHIP.....	14
	4.1 PCI Configuration Registers (PCR)	14
	4.1.1 PCI9030 Header.....	14
	4.2 Local Configuration Register (LCR).....	15
	4.3 Configuration EEPROM	16
	4.4 Local Software Reset	17
5	CONFIGURATION HINTS	18
	5.1 Big / Little Endian.....	18
6	FUNCTIONAL DESCRIPTION	20
7	PROGRAMMING HINTS	21
	7.1 Baud Rate Programming Formula.....	21
8	INSTALLATION HINTS	23
9	PIN ASSIGNMENT – I/O CONNECTOR.....	24
	9.1 Front Panel I/O.....	24
	9.1.1 Connector.....	24
	9.1.2 Front panel I/O Assignment TPMC866-10R / -11R.....	24
	9.2 Back Panel I/O	26
	9.2.1 Mezzanine Card Connector P14	26
	9.2.2 Back panel I/O Assignment TPMC866-10R / -11R	26

List of Figures

FIGURE 1-1 : BLOCK DIAGRAM	6
FIGURE 9-1 : FRONT PANEL I/O CONNECTOR NUMBERING.....	24

List of Tables

TABLE 2-1 : TECHNICAL SPECIFICATION.....	7
TABLE 3-1 : PCI9030 LOCAL SPACE CONFIGURATION	8
TABLE 3-2 : LOCAL REGISTER SPACE 1	8
TABLE 3-3 : SERIAL CHANNEL REGISTER SET BASE ADDRESS.....	9
TABLE 3-4 : CHANNEL REGISTER SET 1	9
TABLE 3-5 : CHANNEL REGISTER SET 2	10
TABLE 3-6 : SPECIAL REGISTER.....	11
TABLE 3-7 : FIFO READY REGISTER 1 (CHANNEL 0-3).....	11
TABLE 3-8 : FIFO READY REGISTER 2 (CHANNEL 4-7).....	12
TABLE 3-9 : INTERRUPT STATUS REGISTER.....	13
TABLE 4-1 : PCI9030 HEADER	14
TABLE 4-2 : PCI9030 LOCAL CONFIGURATION REGISTER	15
TABLE 4-3 : CONFIGURATION EEPROM TPMC866-XX.....	16
TABLE 5-1 : LOCAL BUS LITTLE/BIG ENDIAN	18
TABLE 7-1 : BAUD RATE PROGRAMMING TABLE	21
TABLE 9-1 : I/O CONNECTOR PIN ASSIGNMENT	25
TABLE 9-2 : I/O CONNECTOR PIN ASSIGNMENT	27

1 Product Description

The TPMC866 is a standard single-width 32 bit PMC module and provides eight channels of high performance serial interface with front I/O and P14 back I/O.

The TPMC866-10R provides an 8 channel RS232 interface and supports Receive Data (RxD), Transmit Data (TxD), Ready-To-Send (RTS), Clear-To-Send (CTS) and GND for each channel. Additionally serial channel one and serial channel two provide Data-Set-Ready (DSR), Data-Terminal-Ready (DTR), Data-Carrier-Detect (DCD) and Ring-Detect-Indicator (RI).

The TPMC866-11R provides an 8 channel RS422 interface using differential line transceivers. The Transmit data (TxD +/-), Receive Data (RxD +/-) and GND signals are provided for each serial channel. The receiver signal termination for each channel (120ohm between RxD+ and RxD-) is provided on board the TPMC866.

Each channel of the TPMC866-10R/11R has a 64 byte transmit FIFO and a 64 byte receive FIFO to significantly reduce the overhead required to provide data to and get data from the transmitters and receivers.

The baud rate is individually programmable for up to 460.8Kbaud per channel.

All channels use the PCI interrupt INTA. For fast interrupt source detection the TPMC866-xx provides an Interrupt Status Register covering all interrupt sources.

I/O line transceivers are protected against electrostatic discharge (ESD).

All TPMC866 modules are available in extended temperature range as TPMC866-xx-ET versions.

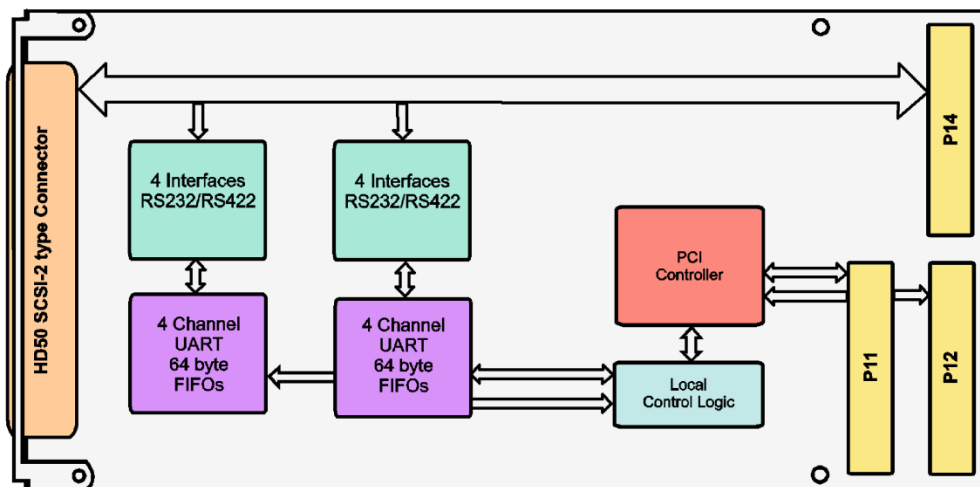

Figure 1-1 : Block Diagram

2 Technical Specification

PMC Interface	
Mechanical Interface	PCI Mezzanine Card (PMC) Interface Single Size
Electrical Interface	PCI Rev. 2.2 compliant, 33 MHz / 32 bit PCI 3,3V and 5V PCI Signaling Voltage
On Board Devices	
PCI Target Chip	PCI9030 (PLX Technology)
Serial Controller	2x ST16C654 (Quad UART) (Exar)
Serial Interface	
Number of Serial Channels	8
Physical Interface	TPMC866-10R: RS232, TPMC866-11R: RS422
I/O Signals	TPMC866-10R: TxD, RxD, RTS, CTS, GND Additionally for Channel 1 and 2: DTR, DSR, DCD, RI TPMC866-11R: TxD+, TxD-, RxD+, RxD-, GND
On Board Termination	TPMC866-11R: 120 ohms between RxD+ and RxD- for each channel
ESD Protection	+/-15kV Human Body Model +/- 8kV IEC 1000-4-2, Contact Discharge (RS232) +/-15kV IEC 1000-4-2, Air-Gap Discharge (RS232)
FIFO	64 byte transmit FIFO, 64 byte receive FIFO per channel
Baud Rates	Each channel programmable for up to 460.8 kbaud
I/O Connector	HD50 SCSI-2 type female connector (front I/O) PMC P14 I/O (64 pin Mezzanine Connector)
Physical Data	
Power Requirements	TPMC866-10R: 15mA typical @ +5V DC 100mA typical @ +3,3V DC TPMC866-11R: 85mA typical @ +5V DC 100mA typical @ +3,3V DC
Temperature Range	TPMC866-10R/-11R: Operating: 0°C to +70 °C Storage: -25°C to +125°C TPMC866-xxR-ET: Operating: -40°C to +85°C Storage: -40°C to +125°C
MTBF	TPMC866-10R: 746000h TPMC866-11R: 722000h MTBF values shown are based on calculation according to MIL-HDBK-217F and MIL-HDBK-217F Notice 2; Environment: G _B 20°C. The MTBF calculation is based on component FIT rates provided by the component suppliers. If FIT rates are not available, MIL-HDBK-217F and MIL-HDBK-217F Notice 2 formulas are used for FIT rate calculation.
Humidity	5 – 95 % non-condensing
Weight	76 g

Table 2-1 : Technical Specification

3 Local Space Addressing

3.1 PCI9030 Local Space Configuration

The local on board addressable regions are accessed from the PCI side by using the PCI9030 local spaces.

PCI9030 Local Space	PCI9030 PCI Base Address (Offset in PCI Configuration Space)	PCI Space Mapping	Size (Byte)	Port Width (Bit)	Endian Mode	Description
0	2 (0x18)	I/O	128	8	Little	Local Register Space 1
1	3 (0x1C)	-	-	-	-	Not Used
2	4 (0x20)	-	-	-	-	Not Used
3	5 (0x24)	-	-	-	-	Not Used

Table 3-1 : PCI9030 Local Space Configuration

3.2 Local Register Space 1

PCI Base Address: PCI9030 PCI Base Address 2 (Offset 0x18 in PCI Configuration Space).

Offset to PCI Base Address 2	Register Name	Access
0x00 to 0x07	Serial Channel 0 Register Set	R/W
0x08 to 0x0F	Serial Channel 1 Register Set	R/W
0x10 to 0x17	Serial Channel 2 Register Set	R/W
0x18 to 0x1F	Serial Channel 3 Register Set	R/W
0x20 to 0x27	Serial Channel 4 Register Set	R/W
0x28 to 0x2F	Serial Channel 5 Register Set	R/W
0x30 to 0x37	Serial Channel 6 Register Set	R/W
0x38 to 0x3F	Serial Channel 7 Register Set	R/W
0x40	FIFO Ready Register CH0-CH3	R/W
0x44	FIFO Ready Register CH4-CH7	R/W
0x48	Interrupt Status Register	R/W

Table 3-2 : Local Register Space 1

3.2.1 Serial Channel Register Set

Each of the 8 serial channels of the TPMC866 is accessed in the TPMC866 Register Space by two register sets. Both register sets have a common register, the Line Control Register (LCR). Bit 7 of the Line Control Register is used to switch between the two register sets of a channel.

Offset (to PCI Base Address) Base Address (for Register Set)	Description
0x00	Serial Channel 0 Register Set
0x08	Serial Channel 1 Register Set
0x10	Serial Channel 2 Register Set
0x18	Serial Channel 3 Register Set
0x20	Serial Channel 4 Register Set
0x28	Serial Channel 5 Register Set
0x30	Serial Channel 6 Register Set
0x38	Serial Channel 7 Register Set

Table 3-3 : Serial Channel Register Set Base Address

3.2.1.1 Channel Register Set 1

Channel Register Set 1 is accessible if bit 7 of the Line Control Register is set to '0'. After reset Channel Register Set 1 is accessible for each channel.

Offset (to Register Set Base Address)	Read Mode	Write Mode	Size (Bit)
0x00	Receive Holding Register	Transmit Holding Register	8
0x01	-	Interrupt Enable Register	8
0x02	Interrupt Status Register	FIFO Control Register	8
0x03	-	Line Control Register (LCR)	8
0x04	-	Modem Control Register	8
0x05	Line Status Register	-	8
0x06	Modem Status Register	-	8
0x07	Scratchpad Register	Scratchpad Register	8

Table 3-4 : Channel Register Set 1

3.2.1.2 Channel Register Set 2

Channel Register Set 2 is accessible if bit 7 of the Line Control Register is set to '1'. The Enhanced Feature Register, Xon-1/2 and Xoff-1/2 registers are accessible if the Line Control Register is set to 0xBF.

Offset (to Register Set Base Address)	Read / Write Mode	Size (Bit)	Access Enable Control
0x00	LSB of Divisor Latch (DLL)	8	LCR bit 7 set to '1' (but ≠ 0xBF)
0x01	MSB of Divisor Latch (DLM)	8	LCR bit 7 set to '1' (but ≠ 0xBF)
0x02	Enhanced Feature Register (EFR)	8	LCR set to 0xBF
0x03	Line Control Register (LCR)	8	Always accessible
0x04	Xon-1 Word	8	LCR set to 0xBF
0x05	Xon-2 Word	8	LCR set to 0xBF
0x06	Xoff-1 Word	8	LCR set to 0xBF
0x07	Xoff-2 Word	8	LCR set to 0xBF

Table 3-5 : Channel Register Set 2

3.2.2 Other Registers

For fast status detection there are two FIFO Status Register (one for channel 0 to 3 and one for channel 4 to 7) and an Interrupt Status Register covering all 8 channels.

Offset	Register Name	Size (Bit)
0x40	FIFO Ready Register 1 (Channel 0-3)	8
0x44	FIFO Ready Register 2 (Channel 4-7)	8
0x48	Interrupt Status Register	8

Table 3-6 : Special Register

3.2.2.1 FIFO Ready 1 Register Channel 0-3

The FIFO Ready Register 1 is a byte wide read only register. The FIFO Ready Register provides the real time status of the transmit and receive FIFO's of channel 0 to 3. Each TX and RX channel (0-3) has its own 64 byte FIFO. When any of the TX/RX FIFO's become empty/full, the status bit associated with the TX/RX function of channel 0-3 is set in the FIFO Ready Register.

Bit	Symbol	Description	Access
7	RXRDY Channel 3	RX Ready Bit for Channel 0-3 0 = the corresponding receive FIFO is above the programmed trigger level or a time-out has occurred 1 = the receiver is ready and is below the programmed trigger level	R
6	RXRDY Channel 2		
5	RXRDY Channel 1		
4	RXRDY Channel 0		
3	TXRDY Channel 3	TX Ready Bit for Channel 0-3 0 = the corresponding transmit FIFO is full. This channel will not accept any more transmit data 1 = one or more empty locations exist in the corresponding FIFO	R
2	TXRDY Channel 2		
1	TXRDY Channel 1		
0	TXRDY Channel 0		

Table 3-7 : FIFO Ready Register 1 (Channel 0-3)

3.2.2.2 FIFO Ready 2 Register Channel 4-7

The FIFO Ready Register FIFORDY2 is a byte wide read only register. The FIFO Ready Register provides the real time status of the transmit and receive FIFO's of channel 4 to 7. Each TX and RX channel (4-7) has its own 64 byte FIFO. When any of the TX/RX FIFO's become empty/full, the status bit associated with the TX/RX function of channel 4-7 is set in the FIFO Ready Register.

Bit	Symbol	Description	Access	Reset Value
7	RXRDY Channel 7	RX Ready Bit for Channel 4-7 0 = the corresponding receive FIFO is above the programmed trigger level or a time-out has occurred 1 = the receiver is ready and is below the programmed trigger level	R	
6	RXRDY Channel 6			
5	RXRDY Channel 5			
4	RXRDY Channel 4			
3	TXRDY Channel 7	TX Ready Bit for Channel 4-7 0 = the corresponding transmit FIFO is full. This channel will not accept any more transmit data 1 = one or more empty locations exist in the corresponding FIFO	R	
2	TXRDY Channel 6			
1	TXRDY Channel 5			
0	TXRDY Channel 4			

Table 3-8 : FIFO Ready Register 2 (Channel 4-7)

3.2.2.3 Interrupt Status Register

The Interrupt Status Register is a byte wide read only register located in the PCI Memory Space (PCI Base Address1 + 0x48) and reflects the interrupt status for the 8 serial channels.

Bit	Symbol	Description	Access	Reset Value
7	Interrupt Channel 7	Interrupt Status of Channel 0-7 0 = no pending interrupt 1 = indicates pending interrupt	R	0x00
6	Interrupt Channel 6			
5	Interrupt Channel 5			
4	Interrupt Channel 4			
3	Interrupt Channel 3			
2	Interrupt Channel 2			
1	Interrupt Channel 1			
0	Interrupt Channel 0			

Table 3-9 : Interrupt Status Register

Each of the 8 serial channels generates interrupts on the local interrupt 1 of the PCI target chip, which is mapped to PCI interrupt INTA.

If PCI interrupts are disabled in the PCI9030 PCI target chip (INTCSR bit 6 is set to '0') the Interrupt Status Register can be used as an interrupt status polling register for the 8 serial channels.

Interrupts of the 8 serial channels can be individually enabled / disabled by the ST16C654 UART registers. After reset all interrupts are disabled.

4 PCI9030 Target Chip

4.1 PCI Configuration Registers (PCR)

4.1.1 PCI9030 Header

PCI CFG Register Address	Write '0' to all unused (Reserved) bits							PCI writeable	Initial Values (Hex Values)	
	31	24	23	16	15	8	7			0
0x00	Device ID				Vendor ID				N	9050 10B5
0x04	Status				Command				Y	0280 0000
0x08	Class Code					Revision ID			N	070200 01
0x0C	BIST	Header Type		PCI Latency Timer		Cache Line Size		Y[7:0]	00 00 00 00	
0x10	PCI Base Address 0 for MEM Mapped Config. Registers							Y	FFFFFFF80	
0x14	PCI Base Address 1 for I/O Mapped Config. Registers							Y	FFFFFFF81	
0x18	PCI Base Address 2 for Local Address Space 0							Y	FFFFFFF81	
0x1C	PCI Base Address 3 for Local Address Space 1							Y	00000000	
0x20	PCI Base Address 4 for Local Address Space 2							Y	00000000	
0x24	PCI Base Address 5 for Local Address Space 3							Y	00000000	
0x28	PCI CardBus Information Structure Pointer							N	00000000	
0x2C	Subsystem ID			Subsystem Vendor ID				N	0362 1498	
0x30	PCI Base Address for Local Expansion ROM							Y	00000000	
0x34	Reserved					New Cap. Ptr.		N	000000 40	
0x38	Reserved							N	00000000	
0x3C	Max_Lat	Min_Gnt		Interrupt Pin		Interrupt Line		Y[7:0]	00 00 01 00	
0x40	PM Cap.			PM Nxt Cap.		PM Cap. ID		N	4801 48 01	
0x44	PM Data		PM CSR EXT		PM CSR			Y	00 00 0000	
0x48	Reserved		HS CSR		HS Nxt Cap.		HS Cap. ID		Y[23:16]	00 00 00 06
0x4C	VPD Address			VPD Nxt Cap.		VPD Cap. ID		Y[31:16]	0000 00 03	
0x50	VPD Data							Y	00000000	

Table 4-1 : PCI9030 Header

Device-ID: 0x9050 (PCI9050)
Vendor-ID: 0x10B5 (PLX Technology)
Subsystem-ID: 0x0362 (TPMC866)
Subvendor-ID: 0x1498 (TEWS TECHNOLOGIES)

4.2 Local Configuration Register (LCR)

After reset, the PCI9030 Local Configuration Registers are loaded from the on board serial configuration EEPROM.

The PCI base address for the PCI9030 Local Configuration Registers is PCI9030 PCI Base Address 0 (PCI Memory Space) (Offset 0x10 in the PCI9030 PCI Configuration Register Space) or PCI9030 PCI Base Address 1 (PCI I/O Space) (Offset 0x14 in the PCI9030 PCI Configuration Register Space).

Do not change hardware dependent bit settings in the PCI9030 Local Configuration Registers.

Offset from PCI Base Address	Register	Value
0x00	Local Address Space 0 Range	0x0FFF_FF81
0x04	Local Address Space 1 Range	0x0000_0000
0x08	Local Address Space 2 Range	0x0000_0000
0x0C	Local Address Space 3 Range	0x0000_0000
0x10	Expansion ROM Range	0x0000_0000
0x14	Local Address Space 0 Local Base Address (Remap)	0x0000_0001
0x18	Local Address Space 1 Local Base Address (Remap)	0x0000_0000
0x1C	Local Address Space 2 Local Base Address (Remap)	0x0000_0000
0x20	Local Address Space 3 Local Base Address (Remap)	0x0000_0000
0x24	Expansion ROM Local Base Address (Remap)	0x0000_0000
0x28	Local Address Space 0 Bus Region Descriptor	0x5411_2880
0x2C	Local Address Space 1 Bus Region Descriptor	0x0000_0000
0x30	Local Address Space 2 Bus Region Descriptor	0x0000_0000
0x34	Local Address Space 3 Bus Region Descriptor	0x0000_0000
0x38	Expansion ROM Bus Region Descriptor	0x0000_0000
0x3C	Chip Select 0 Base Address	0x0000_0021
0x40	Chip Select 1 Base Address	0x0000_0043
0x44	Chip Select 2 Base Address	0x0000_0047
0x48	Chip Select 3 Base Address	0x0000_004B
0x4C	Interrupt Control/Status	0x0041
0x4E	Serial EEPROM Write-Protected Address Boundary	0x0030
0x50	PCI Target Response, Serial EEPROM Control, and Initialization Control	0x0078_0000
0x54	General Purpose I/O Control	0x0000_0246
0x70	Hidden1 Register for Power Management Data Select	0x0000_0000
0x74	Hidden 2 Register for Power Management Data Scale	0x0000_0000

Table 4-2 : PCI9030 Local Configuration Register

4.3 Configuration EEPROM

After power-on or PCI reset, the PCI9030 loads initial configuration register data from the on board configuration EEPROM.

The configuration EEPROM contains the following configuration data:

- Address 0x00 to 0x27 : PCI9030 PCI Configuration Register Values
- Address 0x28 to 0x87 : PCI9030 Local Configuration Register Values
- Address 0x88 to 0xFF : Reserved

See the PCI9030 Manual for more information.

Address	Offset							
	0x00	0x02	0x04	0x06	0x08	0x0A	0x0C	0x0E
0x00	0x9050	0x10B5	0x0280	0x0000	0x0702	0x0000	0x0362	0x1498
0x10	0x0000	0x0040	0x0000	0x0100	0x4801	0x4801	0x0000	0x0000
0x20	0x0000	0x0006	0x0000	0x0003	0x0FFF	0xFF81	0x0000	0x0000
0x30	0x0000	0x0000	0x0000	0x0000	0x0000	0x0000	0x0000	0x0001
0x40	0x0000	0x0000	0x0000	0x0000	0x0000	0x0000	0x0000	0x0000
0x50	0x5411	0x2880	0x0000	0x0000	0x0000	0x0000	0x0000	0x0000
0x60	0x0000	0x0000	0x0000	0x0021	0x0000	0x0043	0x0000	0x0047
0x70	0x0000	0x004B	0x0030	0x0041	0x0078	0x0000	0x0000	0x0246
0x80	0x0000	0x0000	0x0000	0x0000	0xFFFF	0xFFFF	0xFFFF	0xFFFF
0x90	0xFFFF	0xFFFF	0xFFFF	0xFFFF	0xFFFF	0xFFFF	0xFFFF	0xFFFF
0xA0	0xFFFF	0xFFFF	0xFFFF	0xFFFF	0xFFFF	0xFFFF	0xFFFF	0xFFFF
0xB0	0xFFFF	0xFFFF	0xFFFF	0xFFFF	0xFFFF	0xFFFF	0xFFFF	0xFFFF
0xC0	0xFFFF	0xFFFF	0xFFFF	0xFFFF	0xFFFF	0xFFFF	0xFFFF	0xFFFF
0xD0	0xFFFF	0xFFFF	0xFFFF	0xFFFF	0xFFFF	0xFFFF	0xFFFF	0xFFFF
0xE0	0xFFFF	0xFFFF	0xFFFF	0xFFFF	0xFFFF	0xFFFF	0xFFFF	0xFFFF
0xF0	0xFFFF	0xFFFF	0xFFFF	0xFFFF	0xFFFF	0xFFFF	0xFFFF	0xFFFF

Table 4-3 : Configuration EEPROM TPMC866-xx

4.4 Local Software Reset

The PCI9030 Local Reset Output LRESETo# is used to reset the on board local logic.

The PCI9030 local reset is active during PCI reset or if the PCI Adapter Software Reset bit is set in the PCI9030 local configuration register CNTRL (offset 0x50).

CNTRL[30] PCI Adapter Software Reset:

Value of '1' resets the PCI9030 and issues a reset to the Local Bus (LRESETo# asserted). The PCI9030 remains in this reset condition until the PCI Host clears this bit. The contents of the PCI9030 PCI and Local Configuration Registers are not reset. The PCI9030 PCI Interface is not reset.

5 Configuration Hints

5.1 Big / Little Endian

- PCI – Bus (Little Endian)

Byte 0	AD[7..0]
Byte 1	AD[15..8]
Byte 2	AD[23..16]
Byte 3	AD[31..24]

- Every Local Address Space (0...3) and the Expansion ROM Space can be programmed to operate in Big or Little Endian Mode.

Big Endian		Little Endian	
32 Bit		32 Bit	
Byte 0	D[31..24]	Byte 0	D[7..0]
Byte 1	D[23..16]	Byte 1	D[15..8]
Byte 2	D[15..8]	Byte 2	D[23..16]
Byte 3	D[7..0]	Byte 3	D[31..24]
16 Bit upper lane		16 Bit	
Byte 0	D[31..24]	Byte 0	D[7..0]
Byte 1	D[23..16]	Byte 1	D[15..8]
16 Bit lower lane			
Byte 0	D[15..8]		
Byte 1	D[7..0]		
8 Bit upper lane		8 Bit	
Byte 0	D[31..24]	Byte 0	D[7..0]
8 Bit lower lane			
Byte 0	D[7..0]		

Table 5-1 : Local Bus Little/Big Endian

Standard use of the TPMC866:

Local Address Space 0	8 bit bus in Little Endian Mode
Local Address Space 1	not used
Local Address Space 2	not used
Local Address Space 3	not used
Expansion ROM Space	not used

To change the Endian Mode use the Local Configuration Registers for the corresponding Space. Bit 24 of the according register sets the mode. A value of 1 indicates Big Endian and a value of 0 indicates Little Endian.

Use the PCI Base Address 0 + Offset or PCI Base Address 1 + Offset:

Short cut Offset	Name
LAS0BRD	0x28 Local Address Space 0 Bus Region Description Register
LAS1BRD	0x2C Local Address Space 0 Bus Region Description Register
LAS2BRD	0x30 Local Address Space 0 Bus Region Description Register
LAS3BRD	0x34 Local Address Space 0 Bus Region Description Register
EROMBRD	0x38 Expansion ROM Bus Region Description Register

You could also use the PCI - Base Address 1 I/O Mapped Configuration Registers.

6 Functional Description

For a detailed description of the UART functions please refer to the 16C654 UART data sheet (Exar).

7 Programming Hints

7.1 Baud Rate Programming Formula

Each of the 8 serial isolated channels of the TPMC866 contains a programmable baud rate generator. The clock of the ST16C654 can be divided by any divisor from 1 to $2^{16} - 1$. The divisor can be programmed by the LSB and the MSB of the Divisor Latch Register. After reset the MCR bit 7 of each channel is default '0' and the value of LSB and MSB is 0xFFFF.

The basic formula of baud rate programming is:

$$\frac{7.3728MHz}{16 * DIVISOR * (1 + 3 * MCR_BIT7)}$$

Baud Rate MCR bit 7=0	Baud Rate MCR bit 7=1	Divisor (DLM, DLL)
200	50	0x0900
300	75	0x0600
600	150	0x0300
1200	300	0x0180
2400	600	0x00C0
4800	1200	0x0060
9600	2400	0x0030
19.2K	4800	0x0018
28.8K	7200	0x0010
38.4K	9600	0x000C
76.8K	19.2K	0x0006
153.6K	38.4K	0x0003
230.4K	57.6K	0x0002
460.8K	115.2K	0x0001

Table 7-1 : Baud Rate Programming Table

Access to the DLM, DLL registers must be enabled in the LCR register.

These steps should be used to modify the DLM, DLL registers :

- **Write 0x80 to LCR register (enable access to DLM, DLL registers)**
- **Modify DLM, DLL registers**
- **Write normal operation byte value to LCR register**

The MCR (Modem Control Register) bits 5-7 must be enabled for modifying by setting EFR (Enhanced Feature Register) bit 4.

These steps should be used to modify MCR bit 7 :

- Write 0xBF to LCR register (enable access to EFR register)
- Set EFR register bit 4 to '1' (enable modification of MCR bits 5-7)
- Write 0x00 to LCR register (enable access to MCR register)
- Modify MCR bit 7
- Write 0xBF to LCR register (enable access to EFR register)
- Set EFR register bit 4 to '0' (Latch MCR bit setting)
- Write normal operation byte value to LCR register

8 Installation Hints

Connect channel I/O either to front I/O or P14 back I/O at a time. Do not connect an I/O channel to both front I/O connector and P14 back I/O connector at the same time.

The TPMC866-11R (RS422) provides on board 120ohms termination resistors. Do not apply additional external 120ohms termination resistors here.

Please note that on the TPMC866-10R and TPMC866-11R, the P14 back I/O connector is always populated and connected to on board logic. Do not use these modules on carrier boards where P14/J14 is reserved for other system signals but PMC I/O. Ask support for special board options with front I/O only in this case.

9 Pin Assignment – I/O Connector

9.1 Front Panel I/O

9.1.1 Connector

AMP 787395-5 or compatible

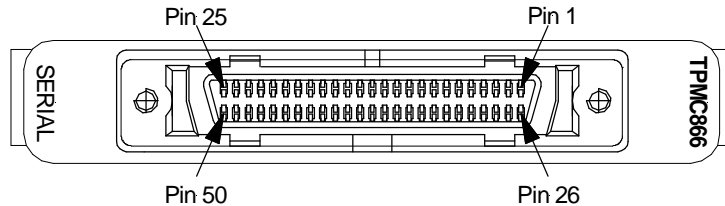

Figure 9-1 : Front Panel I/O Connector Numbering

9.1.2 Front panel I/O Assignment TPMC866-10R / -11R

The subsequent figure shows the complete assembled pin front panel I/O connector.

Pin Number	TPMC866-10R RS232 Interface	TPMC866-11R RS422 Interface	Comment
1	GND	GND	Serial Channel 0
2	TxD0	TxD0-	Serial Channel 0
3	RxD0	TxD+	Serial Channel 0
4	RTS0	RxD0-	Serial Channel 0
5	CTS0	RxD0+	Serial Channel 0
6	GND	GND	Serial Channel 1
7	TxD1	TxD1-	Serial Channel 1
8	RxD1	TxD1+	Serial Channel 1
9	RTS1	RxD1-	Serial Channel 1
10	CTS1	RxD1+	Serial Channel 1
11	GND	GND	Serial Channel 2
12	TxD2	TxD2-	Serial Channel 2
13	RxD2	TxD2+	Serial Channel 2
14	RTS2	RxD2-	Serial Channel 2
15	CTS2	RxD2+	Serial Channel 2
16	GND	GND	Serial Channel 3
17	TxD3	TxD3-	Serial Channel 3
18	RxD3	TxD3+	Serial Channel 3
19	RTS3	RxD3-	Serial Channel 3
20	CTS3	RxD3+	Serial Channel 3
21	GND	GND	Serial Channel 4

Pin Number	TPMC866-10R RS232 Interface	TPMC866-11R RS422 Interface	Comment
22	TxD4	TxD4-	Serial Channel 4
23	RxD4	TxD4+	Serial Channel 4
24	RTS4	RxD4-	Serial Channel 4
25	CTS4	RxD4+	Serial Channel 4
26	GND	GND	Serial Channel 5
27	TxD5	TxD5-	Serial Channel 5
28	RxD5	TxD5+	Serial Channel 5
29	RTS5	RxD5-	Serial Channel 5
30	CTS5	RxD5+	Serial Channel 5
31	GND	GND	Serial Channel 6
32	TxD6	TxD6-	Serial Channel 6
33	RxD6	TxD6+	Serial Channel 6
34	RTS6	RxD6-	Serial Channel 6
35	CTS6	RxD6+	Serial Channel 6
36	GND	GND	Serial Channel 7
37	TxD7	TxD7-	Serial Channel 7
38	RxD7	TxD7+	Serial Channel 7
39	RTS7	RxD7-	Serial Channel 7
40	CTS7	RxD7+	Serial Channel 7
41	GND	GND	Termination Bias Supply
42	+5V	+5V	Termination Bias Supply
43	CD0	-	Data Carrier Detect CH0
44	DTR0	-	Data Terminal Ready CH0
45	RI0	-	Ring Indicator CH0
46	DSR0	-	Data Set Ready CH0
47	CD1	-	Data Carrier Detect CH1
48	DTR1	-	Data Terminal Ready CH1
49	RI1	-	Ring Indicator CH1
50	DSR1	-	Data Set Ready CH1

Table 9-1 : I/O Connector Pin Assignment

9.2 Back Panel I/O

9.2.1 Mezzanine Card Connector P14

MOLEX 71436-216 or compatible

9.2.2 Back panel I/O Assignment TPMC866-10R / -11R

The subsequent figure shows the complete assembled pin back panel I/O connector.

Pin Number	TPMC866-10R RS232 Interface	TPMC866-11R RS422 Interface	Comment
1	GND	GND	Serial Channel 0
2	TxD0	TxD0-	Serial Channel 0
3	RxD0	TxD+	Serial Channel 0
4	RTS0	RxD0-	Serial Channel 0
5	CTS0	RxD0+	Serial Channel 0
6	GND	GND	Serial Channel 1
7	TxD1	TxD1-	Serial Channel 1
8	RxD1	TxD1+	Serial Channel 1
9	RTS1	RxD1-	Serial Channel 1
10	CTS1	RxD1+	Serial Channel 1
11	GND	GND	Serial Channel 2
12	TxD2	TxD2-	Serial Channel 2
13	RxD2	TxD2+	Serial Channel 2
14	RTS2	RxD2-	Serial Channel 2
15	CTS2	RxD2+	Serial Channel 2
16	GND	GND	Serial Channel 3
17	TxD3	TxD3-	Serial Channel 3
18	RxD3	TxD3+	Serial Channel 3
19	RTS3	RxD3-	Serial Channel 3
20	CTS3	RxD3+	Serial Channel 3
21	GND	GND	Serial Channel 4
22	TxD4	TxD4-	Serial Channel 4
23	RxD4	TxD4+	Serial Channel 4
24	RTS4	RxD4-	Serial Channel 4
25	CTS4	RxD4+	Serial Channel 4
26	GND	GND	Serial Channel 5
27	TxD5	TxD5-	Serial Channel 5
28	RxD5	TxD5+	Serial Channel 5
29	RTS5	RxD5-	Serial Channel 5
30	CTS5	RxD5+	Serial Channel 5

Pin Number	TPMC866-10R RS232 Interface	TPMC866-11R RS422 Interface	Comment
31	GND	GND	Serial Channel 6
32	TxD6	TxD6-	Serial Channel 6
33	RxD6	TxD6+	Serial Channel 6
34	RTS6	RxD6-	Serial Channel 6
35	CTS6	RxD6+	Serial Channel 6
36	GND	GND	Serial Channel 7
37	TxD7	TxD7-	Serial Channel 7
38	RxD7	TxD7+	Serial Channel 7
39	RTS7	RxD7-	Serial Channel 7
40	CTS7	RxD7+	Serial Channel 7
41	GND	GND	Termination Bias Supply
42	+5V	+5V	Termination Bias Supply
43	CD0	-	Data Carrier Detect CH0
44	DTR0	-	Data Terminal Ready CH0
45	RI0	-	Ring Indicator CH0
46	DSR0	-	Data Set Ready CH0
47	CD1	-	Data Carrier Detect CH1
48	DTR1	-	Data Terminal Ready CH1
49	RI1	-	Ring Indicator CH1
50	DSR1	-	Data Set Ready CH1
51 ... 64	-	-	-

Table 9-2 : I/O Connector Pin Assignment

Connect channel I/O either to front I/O or P14 back I/O at a time. Do not connect an I/O channel to both front I/O connector and P14 back I/O connector at the same time.

The TPMC866-11R (RS422) provides on board 120ohms termination resistors. Do not apply additional external 120ohms termination resistors here.

Please note that on the TPMC866-10R and TPMC866-11R, the P14 back I/O connector is always populated and connected to on board logic. Do not use these modules on carrier boards where P14/J14 is reserved for other system signals but PMC I/O. Ask support for special board options with front I/O only in this case.