

MVME2500

Freescale QorIQ P2010/P2020 VME64x SBC

Data Sheet

- 800 MHz or 1.2 GHz Freescale QorIQ™ P2010 or P2020 processor based 6U VME board
- 1GB or 2GB DDR3-800, soldered down
- Three on-board Gigabit Ethernet interfaces (one front, one rear, one configurable by customer to front or rear)
- Five serial ports
- One USB 2.0 port
- One PCM/XMC site
- Optional rear transition module
- Hard drive mounting kit available
- Extended temperature (-40 °C to +71 °C) and rugged variants



The Artesyn Embedded Technologies MVME2500 single-board computer (SBC) features the Freescale QorIQ™ P2010 or dual-core P2020. The e500 v2 core QorIQ processor uses 45 nanometer technology, which delivers an industry-leading performance-to-power ratio with single-core or dual-core frequencies up to 1.2 GHz at less than 8W. This is a perfect migration path for our PowerQUICC processor boards (MVME3100 and MVME4100), as well as our G4 processor boards (MVME5100 and MVME5110).

On-board memory includes up to 2GB DDR3 memory and 512 KB non-volatile magneto resistive random access memory. MRAM is high speed non-volatile RAM with unlimited read/write access that protects data in the event of a power loss and does not require periodic refresh. MRAM is ideal for critical non-volatile data storage, data logs, dynamic program updates, and dynamic security. Connectivity includes Gigabit Ethernet, USB 2.0, serial ports, SATA port and one PMC/XMC site. A hard drive mounting kit is available for Serial ATA or solid state hard drives.

The extended temperature models feature an operating temperature range of -40 °C to +71 °C – a significant increase over the standard models' 0 °C to +55 °C range. Acceptable storage temperatures have also been increased, safely accommodating environments from -50 °C to +100 °C. The rugged variants are capable of operating under up to 5G of vibration (15 to 2000 Hz) and can withstand an 11 millisecond shock of up to 30G. Conformal coating is also available. The MVME2500 is ideal for automation, medical, and military applications such as railway control, semiconductor processing, test and measurement, image processing, and radar/sonar.

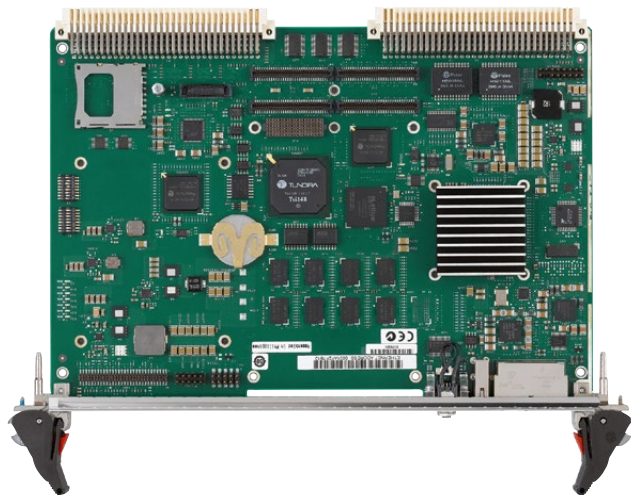

MVME2500 Block Diagram

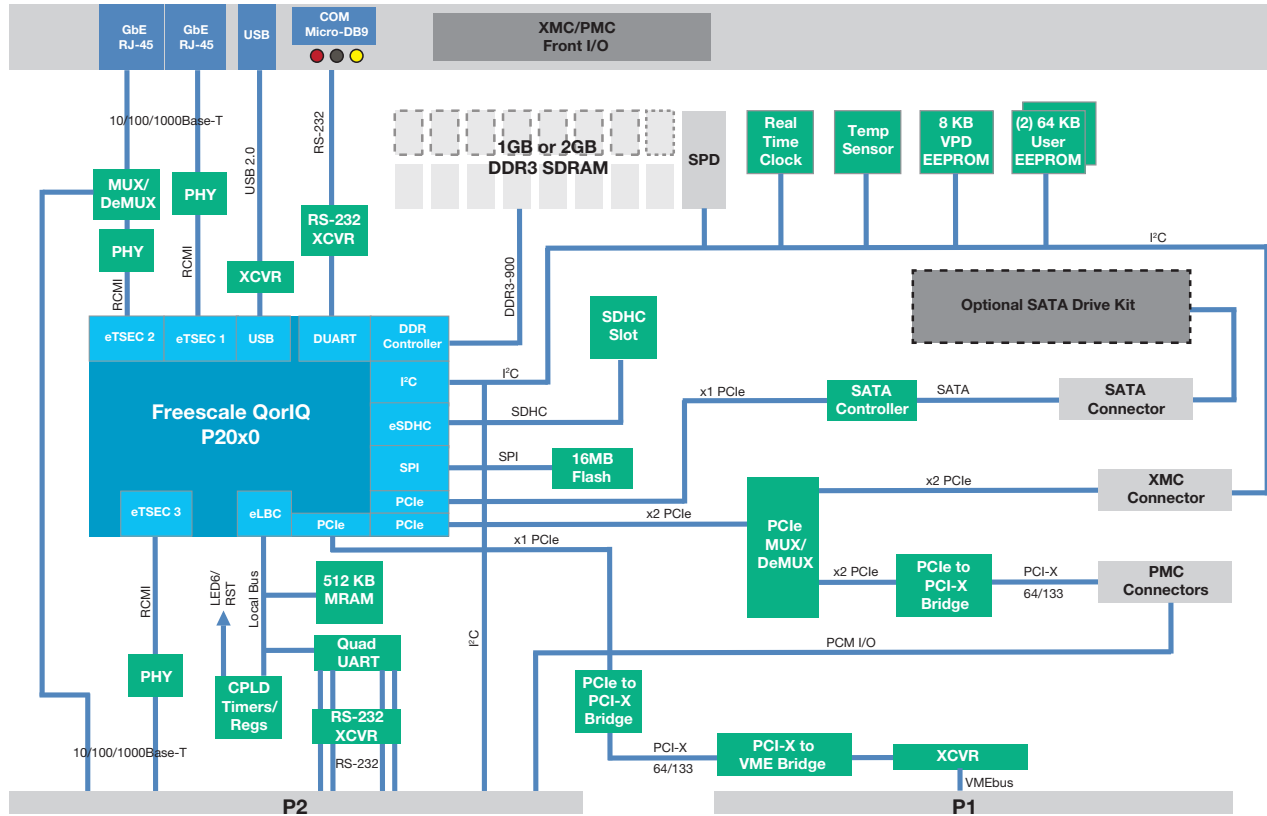

Transition Modules

The MVME7216E transition module provides industry standard connector access to two 10/100/1000BaseTX ports, and four asynchronous serial ports configured as RS-232 DTE. All of these are via RJ-45 connectors. The MVME7216E RTM is designed to directly connect to the VME backplane in chassis with an 80mm deep rear transition area. This transition module is compatible with the MVME3100, MVME4100 and MVME7100 boards.

Software Support

FIRMWARE MONITOR

The MVME2500 uses U-Boot firmware which is resident in the MVME2500 flash and provides power-on self-test, initialization and operating system booting capabilities. It is based on the 2013.01 patched U-Boot provided by Freescale.

OPERATING SYSTEMS AND KERNELS

The MVME2500 supports a variety of operating systems with associated Board Support Packages (BSPs): Fedora 13 Linux (2.6.27 kernel), VxWorks (6.9 SMP) and Linux kernels from Green Hills and LynuxWorks (upon customer request).

Specifications

HARDWARE PROCESSOR/CHIPSET

- 800 MHz Freescale P2010 single-core processor
- 1.2 GHz Freescale P2020 dual-core processor
- 512 KB L2 shared cache
- Integrated, on-chip controllers for DDR2/3, PCI Express, USB 2.0, DUART, 10/100/1000 Ethernet, DMA, SDHC, SPI flash, I²C and security acceleration
- Eight 32-bit timers

MEMORY

- Single channel 800MB/s
- 1GB or 2GB DDR3-800, soldered down

USER FLASH/NVRAM MEMORY

- 512 KB MRAM (NVRAM)
- SDHC socket

BOOT FLASH MEMORY

- 16MB SPI flash (2x 8MB)
- Support for crisis recovery

VMEBUS INTERFACE

- Compliance: ANSI/VITA 1-1994 VME64 (IEEE STD 1014), ANSI/VITA 1.1-1997 VME64 Extensions, VITA 1.5-199x 2eSST
- Controller: Tundra Tsi148 PCI-X to VMEbus bridge with support for VME64 and 2eSST protocols

I/O CAPABILITIES

- Three GbE interfaces (one front, one rear, one configurable to front or rear)
- PMC/XMC (PCI Express x 2)
- Micro DB-9 (front)
- Four RS-232 serial ports (rear)
- USB 2.0 interface (front)
- SATA port for optional on-board hard drive

MVME721 TRANSITION MODULE I/O

- Two GbE interfaces
- Four RS-232 serial ports
- I²C
- PMC I/O

OTHER FEATURES

- Watchdog unit
- Three independent 32-bit tick timers
- Status and user LEDs
- Reset switch

- Locking ejector handles
- Temperature sensors

SOFTWARE

- U-Boot Firmware

POWER REQUIREMENTS

- Maximum for 800 MHz, 1GB memory variant
 - 5.0 V 5 A 25 W (Estimated)
- Maximum for 1.2 GHz, 2GB memory variant
 - 5.0 V 5.7 A 28 W (Estimated)

ENVIRONMENTAL

Ruggedization Level	ENP1	ENP2
Cooling Method	Forced Air	Forced Air
Operating Temperature	0 °C to +55 °C	-40 °C to +71 °C
Storage Temperature	-40 °C to +85 °C	-50 °C to +100 °C
Vibration Sine (10min/axis)	1G, 5 to 200 Hz	5G, 15 to 2000 Hz
Vibration Random (1hr/axis)	.01 g ² /Hz, 15 to 200 Hz	.04g ² /Hz, 15 to 2000 Hz (8 GRMS)
Shock	20 g/11 mS	30g/11 mS
Humidity	to 95% RH	to 100% RH
Conformal Coating*	No	Option (Acrylic)

* Conformal coating these products may result in up to a 2 °C reduction in operating temperature limits.

ELECTROMAGNETIC COMPATIBILITY (EMC)

- Intended for use in systems meeting the following regulations:
 - U.S.: FCC Part 15, Subpart B, Class A (non-residential)
 - Canada: ICES-003, Class A (non-residential)
- Artesyn board products are tested in a representative system to the following standards:
 - CE Mark per European EMC Directive 89/336/EEC with Amendments; Emissions: EN55022 Class B; Immunity: EN55024
 - KCC Mark

DOCUMENTATION

- Installation Guide and Technical Reference Manual
- Hardware Release Notes
- U-Boot Release Notes
- Linux Installation and Programmer's Guides

ESTIMATED MTBF

- MTBF estimated per Telcordia SR-332, issue 2, ground fixed, controlled environment, unit ambient air temperature of 40 °C is between 590,000 hours and 724,000 hours at 60% confidence level depending on memory configuration. Contact Artesyn for alternative environments or temperatures.

Ordering Information

Part Number	Description	Weight
MVME2500-01080101E	QORIQ P2010 800MHZ, 1GB DDR3 IEEE	0.38 kg
MVME2500-01080101S	QORIQ P2010 800MHZ, 1GB DDR3 SCANBE	0.34 kg
MVME2500-02120201E	QORIQ P2020 1200MHZ, 2GB DDR3 IEEE	0.39 kg
MVME2500-02120201S	QORIQ P2020 1200MHZ, 2GB DDR3 SCANBE	0.34 kg
MVME2500-02100202E	QORIQ P2020 1.0GHZ, 2GB DDR3 IEEE, ENP2	0.80 kg
MVME2500-02100202S	QORIQ P2020 1.0GHZ, 2GB DDR3 SCANBE, ENP2	0.53 kg

REAR TRANSITION MODULES

MVME7216E-101	RTM, NEW I/O ON 5 ROW P2, 2 GIGE, 4 SERIAL, PIM, 6E (FOR USE WITH MVME250x/3100/7100/4100)
MVME721ET-101	RTM, NEW I/O ON 5 ROW P2, 2 GIGE, 4 SERIAL, PIM, 6E ENP2 (FOR USE WITH MVME250x/3100/4100/7100)
MVME721ET-102	RTM SCANBE, I/O ON 5 ROW P2, 2 GIGE, 4 SERIAL, PIM, 6E ENP2 (FOR USE WITH MVME250x/3100/4100/7100)

ACCESSORIES AND CABLES

SERIAL-MINI-D2	SERIAL CABLE - MICRO D SUB CONNECTOR TO STANDARD DB9
ACC/CABLE/SER/DTE/6E	SERIAL CABLE, RD 009, 2M, 2 DTE MD/D, RJ-45 TO DB9
VME-HDMNTKIT	VME HD MOUNTING KIT
VME-HDMNTKIT2	VME HD MOUNTING KIT ENP2

SOLUTION SERVICES

Artesyn Embedded Technologies provides a portfolio of solution services optimized to meet your needs throughout the product lifecycle. Design services help speed time-to-market. Deployment services include global 24x7 technical support. Renewal services enable product longevity and technology refresh.

WORLDWIDE OFFICES

Tempe, AZ U.S.A.	+1 888 412 7832	Shanghai, China	+86 21 3395 0289
Munich, Germany	+49 89 9608 2552	Tokyo, Japan	+81 3 5403 2730
Hong Kong	+852 2176 3540	Seoul, Korea	+82 2 3483 1500



www.artesyn.com