

MVME167
Single Board Computer
User's Manual

Contents

CHAPTER 1 GENERAL INFORMATION

Introduction.....	1-1
Model Designations	1-1
Features	1-2
Specifications	1-3
Cooling Requirements	1-3
FCC Compliance.....	1-4
General Description	1-5
Equipment Required	1-6
Related Documentation.....	1-7
Support Information.....	1-8
Manual Terminology.....	1-9

CHAPTER 2 HARDWARE PREPARATION AND INSTALLATION

Introduction.....	2-1
Unpacking Instructions	2-1
Hardware Preparation	2-1
General Purpose Readable Jumpers on Header J1.....	2-2
System Controller Header J2.....	2-2
Serial Port 4 Clock Configuration Select Headers J6 and J7.....	2-4
SRAM Backup Power Source Select Header J8.....	2-5
Installation Instructions.....	2-6
MVME167 Module Installation.....	2-6
System Considerations.....	2-7

CHAPTER 3 OPERATING INSTRUCTIONS

Introduction.....	3-1
Controls and Indicators	3-1
ABORT Switch S1	3-1
RESET Switch S2.....	3-1
Front Panel Indicators (DS1 - DS4).....	3-2
Memory Maps	3-3
Local Bus Memory Map.....	3-3

Normal Address Range	3-3
Detailed I/O Memory Maps	3-6
BBRAM,TOD Clock Memory Map	3-26
Interrupt Acknowledge Map	3-28
VMEbus Memory Map	3-29
VMEbus Accesses to the Local Bus	3-29
VMEbus Short I/O Memory Map	3-29
Software Initialization	3-30
Multi-MPU Programming Considerations	3-30
Local Reset Operation	3-30

CHAPTER 4 FUNCTIONAL DESCRIPTION

Introduction	4-1
MVME167 Functional Description	4-1
Data Bus Structure.....	4-1
MC68040 MPU	4-2
EPROM	4-2
SRAM.....	4-2
Onboard DRAM	4-3
Battery Backed Up RAM and Clock	4-4
VMEbus Interface	4-4
I/O Interfaces	4-5
Serial Port Interface.....	4-5
Parallel Port Interface.....	4-6
Ethernet Interface	4-6
SCSI Interface	4-7
SCSI Termination.....	4-7
Local Resources	4-7
Programmable Tick Timers.....	4-7
Watchdog Timer.....	4-8
Software-Programmable Hardware Interrupts	4-8
Local Bus Timeout.....	4-8
Timing Performance	4-8
Local Bus to DRAM Cycle Times	4-8
ROM Cycle Times	4-9
SCSI Transfers	4-9
LAN DMA Transfers	4-9
Remote Status and Control.....	4-10

APPENDIX A EIA-232-D INTERCONNECTIONS

Introduction.....	A-1
Levels of Implementation	A-3
Signal Adaptations.....	A-3
Sample Configurations	A-4
Proper Grounding	A-6

List of Figures

Figure 2-1. MVME167 Switches, Headers, Connectors, Fuses, and LEDs	2-3
Figure 4-1. MVME167 Main Module Block Diagram	4-11
Figure 4-2. Parity DRAM Mezzanine Module Block Diagram.....	4-12
Figure 4-3. ECC DRAM Mezzanine Module Block Diagram	4-13
Figure A-1. Middle-of-the-Road EIA-232-D Configuration	A-4
Figure A-2. Minimum EIA-232-D Connection	A-5

List of Tables

Table 1-1. MVME167 Model Designations.....	1-1
Table 1-2. MVME167 Specifications	1-4
Table 3-1. Local Bus Memory Map.....	3-4
Table 3-2. Local I/O Devices Memory Map.....	3-5
Table 3-3. VMEchip2 Memory Map (Sheet 1 of 3).....	3-8
Table 3-4. PCCchip2 Memory Map.....	3-14
Table 3-5. Printer Memory Map	3-16
Table 3-6. MEMC040 Internal Register Memory Map	3-17
Table 3-7. MCECC Internal Register Memory Map.....	3-17
Table 3-8. Cirrus Logic CD2401 Serial Port Memory Map	3-19
Table 3-9. 82596CA Ethernet LAN Memory Map	3-23
Table 3-10. 53C710 SCSI Memory Map	3-24
Table 3-11. MK48T08 BBRAM,TOD Clock Memory Map	3-25
Table 3-12. BBRAM Configuration Area Memory Map.....	3-25
Table 3-13. TOD Clock Memory Map.....	3-26
Table A-1. EIA-232-D Interconnections.....	A-2

Introduction

This manual provides general information, preparation for use and installation instructions, operating instructions, and functional description for the MVME167 series of Single Board Computers (referred to as the MVME167 throughout this manual).

Model Designations

The MVME167 is available in several models, which are listed in Table 1-1. *MVME167 Model Designations* on page 1-1.

Table 1-1. MVME167 Model Designations

Model Number	Speed	Major Differences
MVME167-001B (was MVME167-01 or -001A)	25 MHz	4MB Onboard Parity DRAM
MVME167-002B (was MVME167-02 or -002A)	25 MHz	8MB Onboard Parity DRAM
MVME167-003B (was MVME167-03 or -003A)	25 MHz	16MB Onboard Parity DRAM
MVME167-004B (was MVME167-04 or -004A)	25 MHz	32MB Onboard Parity DRAM
MVME167-031B (was MVME167-31 or -031A)	33 MHz	4MB Onboard ECC DRAM
MVME167-032B (was MVME167-32 or -032A)	33 MHz	8MB Onboard ECC DRAM
MVME167-033B (was MVME167-33 or -033A)	33 MHz	16MB Onboard ECC DRAM
MVME167-034B (was MVME167-34 or -034A)	33 MHz	32MB Onboard ECC DRAM
MVME167-035B (was MVME167-035A)	33 MHz	64MB Onboard ECC DRAM
MVME167-036B (was MVME167-036A)	33 MHz	128MB Onboard ECC DRAM

Features

Features of the MVME167 are listed below.

- MC68040 Microprocessor at 25 MHz (-00X models), or 33 MHz (-03X models)
- 4/8/16/32/64MB of 32-bit DRAM with parity protection or 4/8/16/32/64/128/256MB of DRAM with ECC protection
- Four 44-pin PLCC ROM sockets (organized as two banks of 32 bits)
- 128KB SRAM (with optional battery backup)
- Status LEDs for FAIL, STAT, RUN, SCON, LAN, +12V (LAN power), SCSI, and VME.
- 8K by 8 RAM and time of day clock with battery backup
- RESET and ABORT switches
- Four 32-bit tick timers for periodic interrupts
- Watchdog timer
- Eight software interrupts
- I/O
 - SCSI Bus interface with DMA
 - Four serial ports with EIA-232-D buffers with DMA
 - Centronics printer port
 - Ethernet transceiver interface with DMA
- VMEbus interface
 - VMEbus system controller functions
 - VMEbus interface to local bus (A24/A32, D8/D16/D32 (D8/D16/D32/D64BLT) (BLT = Block Transfer)
 - Local bus to VMEbus interface (A16/A24/A32, D8/D16/D32)
 - VMEbus interrupter
 - VMEbus interrupt handler
 - Global CSR for interprocessor communications
 - DMA for fast local memory - VMEbus transfers (A16/A24/A32, D16/D32 (D16/D32/D64BLT)

Specifications

General specifications for the MVME167 are listed in Table 1-2. *MVME167 Specifications* on page 1-4.

The following sections detail cooling requirements and FCC compliance.

Cooling Requirements

The Motorola MVME167 VME module is specified, designed, and tested to operate reliably with an incoming air temperature range from 0° to 55° C (32° to 131° F) with forced air cooling at a velocity typically achievable by using a 100 CFM axial fan. Temperature qualification is performed in a standard Motorola VME system chassis. Twenty-five watt load boards are inserted in two card slots, one on each side, adjacent to the board under test, to simulate a high power density system configuration. An assembly of three axial fans, rated at 100 CFM per fan, is placed directly under the VME card cage. The incoming air temperature is measured between the fan assembly and the card cage, where the incoming airstream first encounters the module under test. Test software is executed as the module is subjected to ambient temperature variations. Case temperatures of critical, high power density integrated circuits are monitored to ensure component vendors specifications are not exceeded.

While the exact amount of airflow required for cooling depends on the ambient air temperature and the type, number, and location of boards and other heat sources, adequate cooling can usually be achieved with 10 CFM and 490 LFM flowing over the module. Less airflow is required to cool the module in environments having lower maximum ambients. Under more favorable thermal conditions, it may be possible to operate the module reliably at higher than 55° C with increased airflow. It is important to note that there are several factors, in addition to the rated CFM of the air mover, which determine the actual volume and speed of air flowing over a module.

Table 1-2. MVME167 Specifications

Characteristics	Specifications
Power requirements (with all four EPROM sockets populated and excluding external LAN transceiver)	+5 Vdc ($\pm 5\%$), 3.5 A (typical), 4.5 A (max.) (at 25 MHz, with 32MB parity DRAM); 5.0 A (typical), 6.5 A (max.) (at 33 MHz, with 128MB ECC DRAM) +12 Vdc ($\pm 5\%$), 100 mA (max.) (1.0 A (max.) with offboard LAN transceiver) -12 Vdc ($\pm 5\%$), 100 mA (max.)
Operating temperature (refer to <i>Cooling Requirements</i> section)	0° to 55° C at point of entry of forced air (approximately 490 LFM)
Storage temperature	-40° to +85° C
Relative humidity	5% to 90% (non-condensing)
Physical dimensions	Double-high VMEboard
PC board with mezzanine module only	
Height	9.187 inches (233.35 mm)
Depth	6.299 inches (160.00 mm)
Thickness	0.662 inches (16.77 mm)
PC boards with connectors and front panel	
Height	10.309 inches (261.85 mm)
Depth	7.4 inches (188 mm)
Thickness	0.80 inches (20.32 mm)

FCC Compliance

The MVME167 was tested in an FCC-compliant chassis, and meets the requirements for Class A equipment. FCC compliance was achieved under the following conditions:

1. Shielded cables on all external I/O ports.
2. Cable shields connected to earth ground via metal shell connectors bonded to a conductive module front panel.
3. Conductive chassis rails connected to earth ground. This provides the path for connecting shields to earth ground.
4. Front panel screws properly tightened.

For minimum RF emissions, it is essential that the conditions above be implemented; failure to do so could compromise the FCC compliance of the equipment containing the module.

General Description

The MVME167 is a double-high VME module based on the MC68040 microprocessor. The MVME167 has 4/8/16/32/64 MB of parity-protected DRAM or 4/8/16/32/64/128/256 MB of ECC-protected DRAM, 8KB of static RAM and time of day clock (with battery backup), Ethernet transceiver interface, four serial ports with EIA-232-D interface, four tick timers, watchdog timer, four ROM sockets, SCSI bus interface with DMA, Centronics printer port, A16/A24/A32/D8/D16/D32/D64 VMEbus master/slave interface, 128KB of static RAM (with optional battery backup), and VMEbus system controller.

The I/O on the MVME167 is connected to the VMEbus P2 connector. The main board is connected through a P2 transition board and cables to the transition boards. The MVME167 supports the transition boards MVME712-12, MVME712-13, MVME712M, MVME712A, MVME712AM, and MVME712B (referred to in this manual as MVME712X, unless separately specified). The MVME712X transition boards provide configuration headers and provide industry standard connectors for the I/O devices.

The VMEbus interface is provided by an ASIC called the VMEchip2. The VMEchip2 includes two tick timers, a watchdog timer, programmable map decoders for the master and slave interfaces, and a VMEbus to/from local bus DMA controller, a VMEbus to/from local bus non-DMA programmed access interface, a VMEbus interrupter, a VMEbus system controller, a VMEbus interrupt handler, and a VMEbus requester.

Processor-to-VMEbus transfers can be D8, D16, or D32. VMEchip2 DMA transfers to the VMEbus, however, can be D16, D32, D16/BLT, D32/BLT, or D64/MBLT.

The PCCchip2 ASIC provides two tick timers and the interface to the LAN chip, SCSI chip, serial port chip, printer port, and BBRAM.

The MEMC040 memory controller ASIC provides the programmable interface for the parity-protected DRAM mezzanine board.

The MCECC memory controller ASIC provides the programmable interface for the ECC-protected DRAM mezzanine board.

Equipment Required

The following equipment is required to make a complete system using the MVME167:

- Terminal
- Disk drives and controllers
- Transition module MVME712-12, MVME712-13, MVME712M, MVME712A, MVME712AM, or MVME712B, and connecting cables and P2 adapter
- Operating system

The MVME167Bug debug monitor firmware (167Bug) is provided in two of the four EPROM sockets on the MVME167 main module. It provides over 50 debug, up/downline load, and disk bootstrap load commands, as well as a full set of onboard diagnostics and a one-line assembler/disassembler. 167Bug includes a user interface which accepts commands from the system console terminal. 167Bug can also operate in a System Mode, which includes choices from a service menu. Refer to the *MVME167Bug Debugging Package User's Manual* and the *Debugging Package for Motorola 68K CISC CPUs User's Manual* for details.

The MVME712X series of transition modules provide the interface between the MVME167 module and peripheral devices. They connect the MVME167 to EIA-232-D serial devices, Centronics-compatible parallel devices, SCSI devices, and Ethernet devices. The MVME712X series work with cables and a P2 adapter.

Software available for the MVME167 includes SYSTEM V/68 and real-time operating systems, programming languages, and other tools and applications. Contact your local Motorola sales office for more details.

Related Documentation

The following publications are applicable to the MVME167 and may provide additional helpful information. If not shipped with this product, they may be purchased by contacting your local Motorola sales office. Non-Motorola documents may be purchased from the sources listed.

Document Title	Motorola Publication Number
MVME167 Single Board Computer Support Information (Refer to <i>Support Information</i> on page 1-8)	SIMVME167
MVME167Bug Debugging Package User's Manual	MVME167BUG
Debugging Package for Motorola 68K CISC CPUs User's Manual	68KBUG
Single Board Computers SCSI Software User's Manual	SBCSCSI
MVME166/MVME167/MVME187 Single Board Computers Programmer's Reference Guide	MVME187PG
MVME712M Transition Module and P2 Adapter Board User's Manual	MVME712M
MVME712-12, MVME712-13, MVME712A, MVME712AM, and MVME712B Transition Module and LCP2 Adapter Board User's Manual	MVME712A
M68040 Microprocessor User's Manual	M68040UM

Note

Although not shown in the above list, each Motorola Computer Group manual publication number is suffixed with characters which represent the revision level of the document, such as "/D2" (the second revision of a manual); a supplement bears the same number as a manual but has a suffix such as "/D2A1" (the first supplement to the second edition of the manual).

The following publications are available from the sources indicated.

Versatile Backplane Bus: VMEbus, ANSI/IEEE Std 1014-1987, The Institute of Electrical and Electronics Engineers, Inc., 345 East 47th Street, New York, NY 10017 (VMEbus Specification). This is also available as *Microprocessor system bus for 1 to 4 byte data, IEC 821 BUS*, Bureau Central de la Commission Electrotechnique Internationale; 3, rue de Varembe, Geneva, Switzerland.

ANSI Small Computer System Interface-2 (SCSI-2), Draft Document X3.131-198X, Revision 10c; Global Engineering Documents, P.O. Box 19539, Irvine, CA 92714.

CL-CD2400/2401 Four-Channel Multi-Protocol Communications Controller Data Sheet, order number 542400-003; Cirrus Logic, Inc., 3100 West Warren Ave., Fremont, CA 94538.

82596CA Local Area Network Coprocessor Data Sheet, order number 290218; and *82596 User's Manual*, order number 296853; Intel Corporation, Literature Sales, P.O. Box 58130, Santa Clara, CA 95052-8130.

NCR 53C710 SCSI I/O Processor Data Manual, order number NCR53C710DM; and *NCR 53C710 SCSI I/O Processor Programmer's Guide*, order number NCR53C710PG; NCR Corporation, Microelectronics Products Division, Colorado Springs, CO.

MK48T08(B) Timekeeper TM and 8Kx8 Zeropower TM RAM data sheet in Static RAMs Databook, order number DBSRAM71; SGS-THOMPSON Microelectronics Group; North & South American Marketing Headquarters, 1000 East Bell Road, Phoenix, AZ 85022-2699.

Support Information

The SIMVME167 manual contains the connector interconnect signal information, parts lists, and the schematics for the MVME167.

This manual may be obtained free of charge by contacting your local Motorola sales office.

Manual Terminology

Throughout this manual, a convention is used which precedes data and address parameters by a character identifying the numeric format as follows:

\$	dollar	specifies a hexadecimal character
%	percent	specifies a binary number
&	ampersand	specifies a decimal number

Unless otherwise specified, all address references are in hexadecimal.

An asterisk (*) following the signal name for signals which are level significant denotes that the signal is true or valid when the signal is low.

An asterisk (*) following the signal name for signals which are edge significant denotes that the actions initiated by that signal occur on high to low transition.

In this manual, assertion and negation are used to specify forcing a signal to a particular state. In particular, assertion and assert refer to a signal that is active or true; negation and negate indicate a signal that is inactive or false. These terms are used independently of the voltage level (high or low) that they represent.

Data and address sizes are defined as follows:

- A byte is eight bits, numbered 0 through 7, with bit 0 being the least significant.
- A word is 16 bits, numbered 0 through 15, with bit 0 being the least significant.
- A longword is 32 bits, numbered 0 through 31, with bit 0 being the least significant.

Introduction

This chapter provides unpacking instructions, hardware preparation, and installation instructions for the MVME167. The MVME712X transition module hardware preparation is provided in separate manuals. Refer to *Related Documentation* in Chapter 1.

Unpacking Instructions

Note If the shipping carton is damaged upon receipt, request carrier's agent be present during unpacking and inspection of equipment.

Unpack equipment from shipping carton. Refer to packing list and verify that all items are present. Save packing material for storing and reshipping of equipment.

Caution Avoid touching areas of integrated circuitry; static discharge can damage circuits.

Hardware Preparation

To select the desired configuration and ensure proper operation of the MVME167, certain option modifications may be necessary before installation. The MVME167 provides software control for most of these options. Some options can not be done in software, so are done by jumpers on headers. Most other modifications are done by setting bits in control registers after the MVME167 has been installed in a system. (The MVME167 registers are described in *Chapter 4*, and/or in the *MVME166/MVME167/MVME187 Single Board Computers Programmer's Reference Guide* as listed in *Related Documentation* in Chapter 1.)

The location of the switches, jumper headers, connectors, and LED indicators on the MVME167 is illustrated in Figure 2-1. The MVME167 has been factory tested and is shipped with the factory jumper settings described in the following sections. The MVME167 operates with its required and factory-installed Debug Monitor, MVME167Bug (167Bug), with these factory jumper settings.

Settings can be made for:

- General purpose readable register (J1)

- System controller select (J2)
- Serial port 4 clock configuration select (J6 and J7)
- SRAM backup power source select (J8) (optional)

General Purpose Readable Jumpers on Header J1

Each MVME167 may be configured with readable jumpers. These jumpers can be read as a register (at \$FFF40088) in the VMEchip2 LCSR. The bit values are read as a one when the jumper is off, and as a zero when the jumper is on.

J1

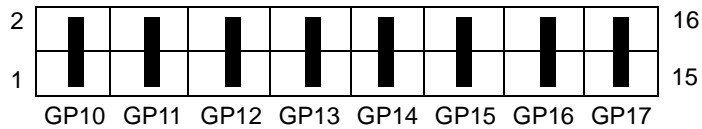

All Zeros (Factory Configuration)

System Controller Header J2

The MVME167 can be VMEbus system controller. The system controller function is enabled/disabled by jumpers on header J2. When the MVME167 is system controller, the SCON LED is turned on. The VMEchip2 may be configured as a system controller as follows.

J2

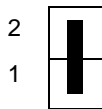

System Controller
(Factory Configuration)

J2

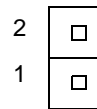

Not System Controller

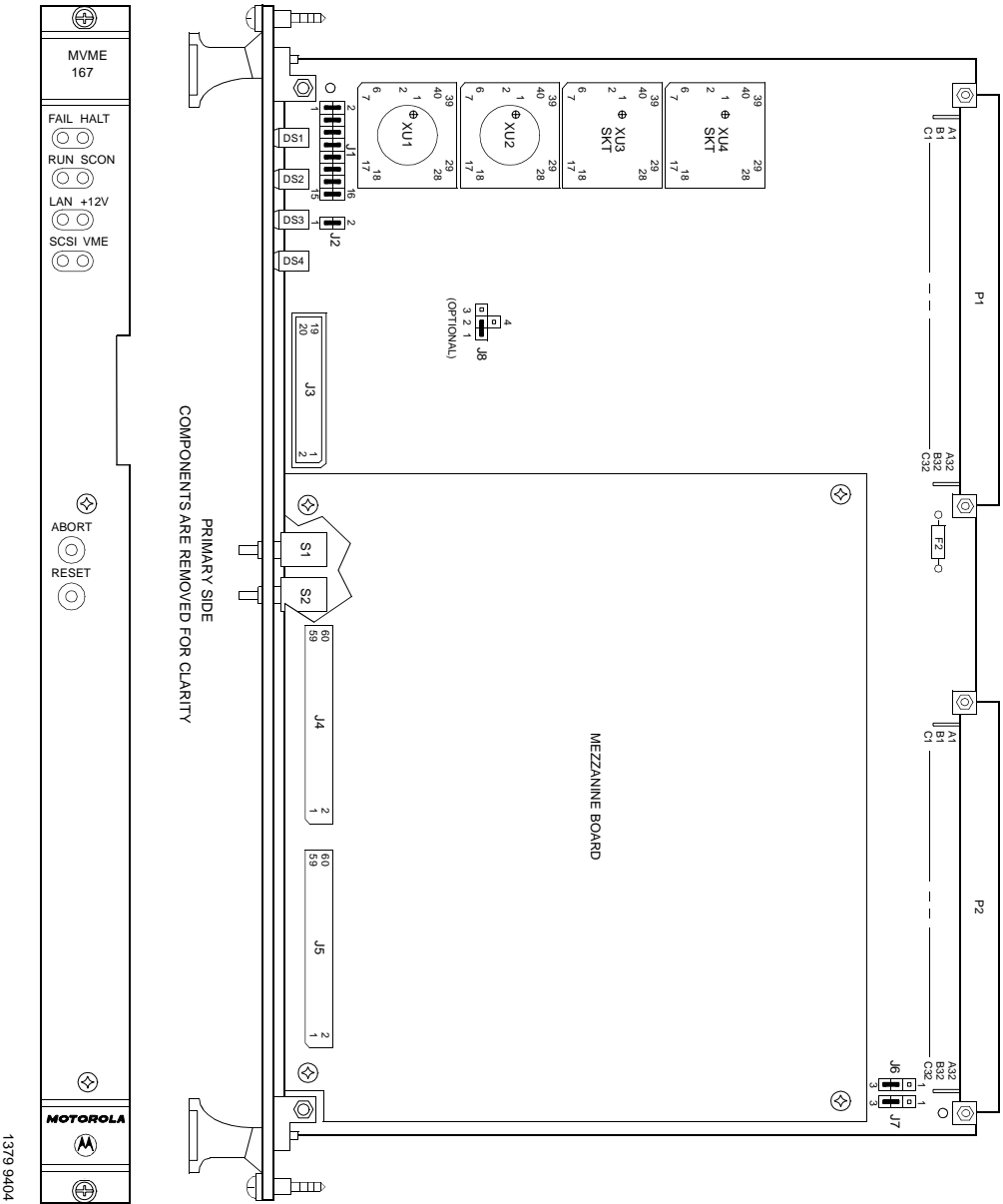
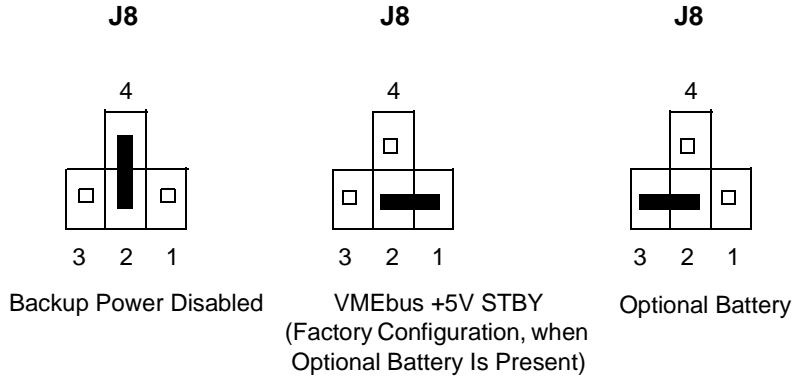

Figure 2-1. MVME167 Switches, Headers, Connectors, Fuses, and LEDs

SRAM Backup Power Source Select Header J8

Header J8 is an optional header that is used to select the power source used to back up the SRAM on the MVME167, if the optional battery and circuitry is present.



Caution Do not remove all jumpers from J8. This may disable the SRAM.

If your board contains the optional header J8, but the optional battery is removed, jumpers must be installed on J8 between pins 2 and 4, as shown in the Backup Power Disabled drawing above.

Installation Instructions

The following sections discuss installation of the MVME167 into a VME chassis, and system considerations. Ensure that EPROM devices are installed as needed. Factory configuration is with two EPROMs installed for the MVME167Bug debug monitor, in sockets XU1 and XU2. Ensure that all header jumpers are configured as desired.

MVME167 Module Installation

Now that the MVME167 module is ready for installation, proceed as follows:

1. Turn all equipment power OFF and disconnect power cable from ac power source.

Caution Inserting or removing modules while power is applied could result in damage to module components. **WARNING**



DANGEROUS VOLTAGES, CAPABLE OF CAUSING DEATH, ARE PRESENT IN THIS EQUIPMENT. USE EXTREME CAUTION WHEN HANDLING, TESTING, AND ADJUSTING.

2. Remove chassis cover as instructed in the equipment user's manual.
3. Remove the filler panel(s) from the appropriate card slot(s) at the front and rear of the chassis (if the chassis has a rear card cage). The MVME167 module requires power from both P1 and P2. It may be installed in any double-height unused card slot, if it is not configured as system controller. If the MVME167 is configured as system controller, it must be installed in the leftmost card slot (slot 1) to correctly initiate the bus-grant daisy-chain and to have proper operation of the IACK-daisy-chain driver. The MVME167 is to be installed in the front of the chassis and the MVME712X is to be installed in the front or the rear of the chassis. Other modules in the system may have to be moved to allow space for the MVME712M which has a double-wide front panel.
4. Carefully slide the MVME167 module into the card slot. Be sure the module is seated properly into the P1 and P2 connectors on the backplane. Do not damage or bend connector pins. Fasten the module in the chassis with screws provided, making good contact with the transverse mounting rails to minimize RFI emissions.
5. Remove IACK and BG jumpers from the header on the chassis backplane for the card slot the MVME167 is installed in.

6. Connect the P2 Adapter Board and specified cable(s) to the MVME167 at P2 on the backplane at the MVME167 slot, to mate with (optional) terminals or other peripherals at the EIA-232-D serial ports, parallel port, SCSI ports, and LAN Ethernet port. Refer to the manuals listed in *Related Documentation* in Chapter 1 for information on installing the P2 Adapter Board and the MVME712X transition module(s). (Some connection diagrams are in the *MVME166/MVME167/MVME187 Single Board Computers Programmer's Reference Guide*.) Some cable(s) are not provided with the MVME712X module(s), and therefore are made or provided by the user. (Motorola recommends using shielded cables for all connections to peripherals to minimize radiation.) Connect the peripherals to the cable(s). Detailed information on the EIA-232-D signals supported is found in Appendix A.
7. Install any other required VME modules in the system.
8. Replace the chassis cover.
9. Connect power cable to ac power source and turn equipment power ON.

System Considerations

The MVME167 needs to draw power from both P1 and P2 of the VMEbus backplane. P2 is also used for the upper 16 bits of data for 32-bit transfers, and for the upper 8 address lines for extended addressing mode. The MVME167 may not operate properly without its main board connected to P1 and P2 of the VMEbus backplane.

Whether the MVME167 operates as a VMEbus master or as a VMEbus slave, it is configured for 32 bits of address and for 32 bits of data (A32/D32). However, it handles A16 or A24 devices in the address ranges indicated in *Chapter 3*. D8 and/or D16 devices in the system must be handled by the MC68040 software. Refer to the memory maps in *Chapter 3*.

The MVME167 contains shared onboard DRAM whose base address is software-selectable. Both the onboard processor and offboard VMEbus devices see this local DRAM at base physical address \$00000000, as programmed by the MVME167Bug firmware. This may be changed, by software, to any other base address. Refer to the *MVME166/MVME167/MVME187 Single Board Computers Programmer's Reference Guide* for details.

If the MVME167 tries to access offboard resources in a nonexistent location, and is not system controller, and if the system does not have a global bus timeout, the MVME167 waits forever for the VMEbus cycle to complete. This would cause the system to hang up. There is only one situation in which the system might lack this global bus timeout: the MVME167 is not the system controller, and there is no global bus timeout elsewhere in the system.

Multiple MVME167 modules may be configured into a single VME card cage. In general, hardware multiprocessor features are supported.

Other MPUs on the VMEbus can interrupt, disable, communicate with and determine the operational status of the processor(s). One register of the GCSR set includes four bits which function as location monitors to allow one MVME167 processor to broadcast a signal to other MVME167 processors, if any. All eight registers are accessible from any local processor as well as from the VMEbus.

The MVME167 provides +12 Vdc power to the Ethernet LAN transceiver interface through a 1 amp fuse F2 located on the MVME167 module. The +12V LED lights when +12 Vdc is available. The fuse is socketed, and located near diode CR1. If the Ethernet transceiver fails to operate, check the fuse. When using the MVME712M module, the yellow LED (DS1) on the MVME712M front panel lights when LAN power is available, indicating that the fuse is good.

The MVME167 provides SCSI terminator power through a 1 amp fuse F1 located on the P2 Adapter Board. The fuse is socketed. If the fuse is blown, the SCSI devices may not operate or may function erratically. When the P2 Adapter Board is used with an MVME712M and the SCSI bus is connected to the MVME712M, the green LED (DS2) on the MVME712M front panel lights when there is SCSI terminator power. If the LED flickers during SCSI bus operation, the fuse should be checked.

Introduction

This chapter provides necessary information to use the MVME167 module in a system configuration. This includes controls and indicators, memory maps, and software initialization of the module.

Controls and Indicators

The MVME167 module has ABORT and RESET switches; and FAIL, STAT, RUN, SCON, LAN,+12V (LAN power), SCSI, and VME indicators; all located on the front panel of the module.

ABORT Switch S1

When enabled by software, the front panel ABORT switch generates an interrupt at a user-programmable level. It is normally used to abort program execution and return to the 167Bug debugger firmware located in the MVME167 EPROMs.

The ABORT switch interrupter in the VMEchip2 is an edge-sensitive interrupter connected to the ABORT switch. This interrupter is filtered to remove switch bounce.

RESET Switch S2

The front panel RESET switch resets all onboard devices, and drives SYSRESET* if the board is system controller. The RESET switch may be disabled by software.

The VMEchip2 includes both a global and a local reset driver. When the chip operates as the VMEbus system controller, the reset driver provides a global system reset by asserting the VMEbus signal SYSRESET*. A SYSRESET* may be generated by the RESET switch, a power up reset, a watchdog timeout, or by a control bit in the LCSR. SYSRESET* remains asserted for at least 200 msec, as required by the VMEbus specification.

Similarly, the VMEchip2 provides an input signal and a control bit to initiate a local reset operation. By setting a control bit, software can maintain a board in a reset state, disabling a faulty board from participating in normal system operation. The local reset driver is enabled even when the VMEchip2 is not the system controller. A local reset may be generated by the RESET switch, a power up reset, a watchdog timeout, a VMEbus SYSRESET*, or a control bit in the GCSR.

Front Panel Indicators (DS1 - DS4)

There are eight LEDs on the MVME167 front panel: FAIL, STAT, RUN, SCON, LAN, +12V (LAN power), SCSI, and VME.

- ❑ The red FAIL LED (part of DS1) lights when the BRDFAIL signal line is active.
- ❑ The MC68040 status lines are decoded, on the MVME167, to drive the yellow STAT (status) LED (part of DS1). In this case, a halt condition from the processor lights the LED.
- ❑ The green RUN LED (part of DS2) lights when the local bus TIP* signal line is low. This indicates one of the local bus masters is executing a local bus cycle.
- ❑ The green SCON LED (part of DS2) lights when the VMEchip2 in the MVME167 is the VMEbus system controller.
- ❑ The green LAN LED (part of DS3) lights when the LAN chip is local bus master.
- ❑ The MVME167 supplies +12V power to the Ethernet transceiver interface through a fuse. The green +12V (LAN power) LED (part of DS3) lights when power is available to the transceiver interface.
- ❑ The green SCSI LED (part of DS4) lights when the SCSI chip is local bus master.
- ❑ The green VME LED (part of DS4) lights when the board is using the VMEbus (VMEbus AS* is asserted by the VMEchip2) or when the board is accessed by the VMEbus (VMEchip2 is the local bus master).

Memory Maps

There are two points of view for memory maps: 1) the mapping of all resources as viewed by local bus masters (local bus memory map), and 2) the mapping of onboard resources as viewed by VMEbus Masters (VMEbus memory map).

Local Bus Memory Map

The local bus memory map is split into different address spaces by the transfer type (TT) signals. The local resources respond to the normal access and interrupt acknowledge codes.

Normal Address Range

The memory map of devices that respond to the normal address range is shown in the following tables. The normal address range is defined by the Transfer Type (TT) signals on the local bus. On the MVME167, Transfer Types 0, 1, and 2 define the normal address range.

Table 3-1. *Local Bus Memory Map*, is the entire map from \$00000000 to \$FFFFFFF. Many areas of the map are user-programmable, and suggested uses are shown in the table. The cache inhibit function is programmable in the MMUs. The onboard I/O space must be marked cache inhibit and serialized in its page table.

Table 3-2. *Local I/O Devices Memory Map* on page 3-5 further defines the map for the local I/O devices.

Table 3-1. Local Bus Memory Map

Address Range	Devices Accessed	Port Size	Size	Software Cache Inhibit	Notes
\$00000000 - DRAMSIZE	User Programmable (Onboard DRAM)	D32	DRAMSIZE	N	1, 2
DRAMSIZE - \$FF7FFFFFFF	User Programmable (VMEbus)	D32/D16	3GB	?	3, 4
\$FF800000 - \$FFBFFFFFFF	ROM	D32	4MB	N	1
\$FFC00000 - \$FFDFFFFFFF	reserved	--	2MB	--	5
\$FFE00000 - \$FFE1FFFF	SRAM	D32	128KB	N	--
\$FFE20000 - \$FFEFFFFF	SRAM (repeated)	D32	896KB	N	--
\$FFF00000 - \$FFFFFFFFFF	Local I/O Devices (Refer to next table)	D32-D8	1MB	Y	3
\$FFFF0000 - \$FFFFFFF	User Programmable (VMEbus A16)	D32/D16	64KB	?	2, 4

- NOTES:
1. Onboard EPROM appears at \$00000000 - \$003FFFFFFF following a local bus reset. The EPROM appears at 0 until the ROM0 bit is cleared in the VMEchip2. The ROM0 bit is located at address \$FFF40030 bit 20. The EPROM must be disabled at 0 before the DRAM is enabled. The VMEchip2 and DRAM map decoders are disabled by a local bus reset.
 2. This area is user-programmable. The suggested use is shown in the table. The DRAM decoder is programmed in the MEMC040 or MCECC chip, and the local-to-VMEbus decoders are programmed in the VMEchip2.
 3. Size is approximate.
 4. Cache inhibit depends on devices in area mapped.
 5. This area is not decoded. If these locations are accessed and the local bus timer is enabled, the cycle times out and is terminated by a TEA signal.

The following table focuses on the Local I/O Devices portion of the local bus Main Memory Map.9.

Table 3-2. Local I/O Devices Memory Map

Address Range	Devices Accessed	Port Size	Size	Notes
\$FFF00000 - \$FFF3FFFF	reserved	--	256KB	5
\$FFF40000 - \$FFF400FF	VMEchip2 (LCSR)	D32	256B	1,4
\$FFF40100 - \$FFF401FF	VMEchip2 (GCSR)	D32-D8	256B	1,4
\$FFF40200 - \$FFF40FFF	reserved	--	3.5KB	5,7
\$FFF41000 - \$FFF41FFF	reserved	--	4KB	5
\$FFF42000 - \$FFF42FFF	PCCchip2	D32-D8	4KB	1
\$FFF43000 - \$FFF430FF	MEMC040/MCECC #1	D8	256B	1
\$FFF43100 - \$FFF431FF	MEMC040/MCECC #2	D8	256B	1
\$FFF43200 - \$FFF43FFF	MEMC040s/MCECCs (repeated)	--	3.5KB	1,7
\$FFF44000 - \$FFF44FFF	reserved	--	4KB	5
\$FFF45000 - \$FFF451FF	CD2401 (Serial Comm. Cont.)	D16-D8	512B	1,9
\$FFF45200 - \$FFF45DFF	reserved	--	3KB	7,9
\$FFF45E00 - \$FFF45FFF	reserved	--	512B	1,9
\$FFF46000 - \$FFF46FFF	82596CA (LAN)	D32	4KB	1,8
\$FFF47000 - \$FFF47FFF	53C710 (SCSI)	D32/D8	4KB	1
\$FFF48000 - \$FFF4FFFF	reserved	--	32KB	5
\$FFF50000 - \$FFF6FFFF	reserved	--	128KB	5
\$FFF70000 - \$FFF76FFF	reserved	--	28KB	6
\$FFF77000 - \$FFF77FFF	reserved	--	4KB	2
\$FFF78000 - \$FFF7EFFF	reserved	--	28KB	6
\$FFF7F000 - \$FFF7FFFF	reserved	--	4KB	2
\$FFF80000 - \$FFF9FFFF	reserved	--	128KB	6
\$FFFA0000 - \$FFFBFFFF	reserved	--	128KB	5
\$FFFC0000 - \$FFFCFFFF	MK48T08 (BBRAM, TOD Clock)	D32-D8	64KB	1
\$FFFD0000 - \$FFFDFFFF	reserved	--	64KB	5
\$FFFE0000 - \$FFFEFFFF	reserved	--	64KB	2

- NOTES:
1. For a complete description of the register bits, refer to the data sheet for the specific chip. For a more detailed memory map refer to the following detailed peripheral device memory maps.
 2. On the MVME167 this area does not return an acknowledge signal. If the local bus timer is enabled, the access times out and is terminated by a TEA signal.

3. Byte reads should be used to read the interrupt vector. These locations do not respond when an interrupt is not pending. If the local bus timer is enabled, the access times out and is terminated by a TEA signal.
4. Writes to the LCSR in the VMEchip2 must be 32 bits. LCSR writes of 8 or 16 bits terminate with a TEA signal. Writes to the GCSR may be 8, 16 or 32 bits. Reads to the LCSR and GCSR may be 8, 16 or 32 bits.
5. This area does not return an acknowledge signal. If the local bus timer is enabled, the access times out and is terminated by a TEA signal.
6. This area does return an acknowledge signal.
7. Size is approximate.
8. Port commands to the 82596CA must be written as two 16-bit writes: upper word first and lower word second.
9. The CD2401 appears repeatedly from \$FFF45200 to \$FFF45FFF on the MVME167. If the local bus timer is enabled, the access times out and is terminated by a TEA signal.



Detailed I/O Memory Maps

Tables 3-3 through 3-13 give the detailed memory maps for:

3-3 VMEchip2	3-9 82596CA Ethernet chip
3-4 PCCchip2	3-10 53C710 SCSI chip
3-5 Printer	3-11 MK48T08 BBRAM/TOD clock
3-6 MEMC040 memory controller chip	3-12 BBRAM configuration area
3-7 MCECC memory controller chip	3-13 TOD clock
3-8 CD2401 serial chip	

Note: Manufacturers' errata sheets for the various chips are available by contacting your local Motorola sales representative. A non-disclosure agreement may be required.

This page intentionally left blank.

15	14	13	12	11	10	9	8	7	6	5	4	3	2	1	0	
SLAVE STARTING ADDRESS 1																
SLAVE STARTING ADDRESS 2																
SLAVE ADDRESS TRANSLATION SELECT 1																
SLAVE ADDRESS TRANSLATION SELECT 2																
				ADDER 1	SNP 1	WP 1	SUP 1	USR 1	A32 1	A24 1	BLK D64 1	BLK 1	PRGM 1	DATA 1		
15	14	13	12	11	10	9	8	7	6	5	4	3	2	1	0	
MASTER STARTING ADDRESS 1																
MASTER STARTING ADDRESS 2																
MASTER STARTING ADDRESS 3																
MASTER STARTING ADDRESS 4																
MASTER ADDRESS TRANSLATION SELECT 4																
MAST D16 EN	MAST WP EN	MASTER AM 2						MAST D16 EN	MAST WP EN	MASTER AM 1						
IO2 EN	IO2 WP EN	IO2 S/U	IO2 P/D	IO1 EN	IO1 D16 EN	IO1 WP EN	IO1 S/U	ROM SIZE	ROM BANK B SPEED			ROM BANK A SPEED				
15	14	13	12	11	10	9	8	7	6	5	4	3	2	1	0	
ARB ROBN	MAST DHB	MAST DWB		MST FAIR	MST RWD	MASTER VMEBUS		DMA HALT	DMA EN	DMA TBL	DMA FAIR	DM RELM		DMA VMEBUS		
DMA TBL INT	DMA LB SNP MODE			DMA INC VME	DMA INC LB	DMA WRT	DMA D16	DMA D64 BLK	DMA BLK	DMA AM 5	DMA AM 4	DMA AM 3	DMA AM 2	DMA AM 1	DMA AM 0	
LOCAL BUS ADDRESS COUNTER																
VMEBUS ADDRESS COUNTER																
BYTE COUNTER																
TABLE ADDRESS COUNTER																
DMA TABLE INTERRUPT COUNT				MPU CLR STAT	MPU LBE ERR	MPU LPE ERR	MPU LOB ERR	MPU LTO ERR	DMA LBE ERR	DMA LPE ERR	DMA LOB ERR	DMA LTO ERR	DMA TBL ERR	DMA VME ERR	DMA DONE	

1360 9403

← This sheet begins on facing page.

Table 3-3. VMEchip2 Memory Map (Sheet 2 of 3)

**VMEchip2 LCSR Base Address = \$FFF40000
OFFSET:**

	31	30	29	28	27	26	25	24	23	22	21	20	19	18	17	16	
4C	ARB BGTO EN							DMA TIME OFF				DMA TIME ON			VME GLOBAL TIMER		
50	TICK TIMER 1																
54	TICK TIMER 1																
58	TICK TIMER 2																
5C	TICK TIMER 2																
60	X	SCON	SYS FAIL	BRD FAIL STAT	PURS STAT	CLR PURS STAT	BRD FAIL OUT	RST SW EN	SYS RST	WD CLR TO	WD CLR CNT	WD TO STAT	TO BF EN	WD SRST LRST	WD RST EN	WD EN	
64	PRE																
	31	30	29	28	27	26	25	24	23	22	21	20	19	18	17	16	
68	AC FAIL IRQ	AB IRQ	SYS FAIL IRQ	MWP BERR IRQ	PE IRQ	IRQ1E IRQ	TIC2 IRQ	TIC1 IRQ	VME IACK IRQ	DMA IRQ	SIG3 IRQ	SIG2 IRQ	SIG1 IRQ	SIG0 IRQ	LM1 IRQ	LM0 IRQ	
6C	EN IRQ 31	EN IRQ 30	EN IRQ 29	EN IRQ 28	EN IRQ 27	EN IRQ 26	EN IRQ 25	EN IRQ 24	EN IRQ 23	EN IRQ 22	EN IRQ 21	EN IRQ 20	EN IRQ 19	EN IRQ 18	EN IRQ 17	EN IRQ 16	
70	(Crossed out)																
74	CLR IRQ 31	CLR IRQ 30	CLR IRQ 29	CLR IRQ 28	CLR IRQ 27	CLR IRQ 26	CLR IRQ 25	CLR IRQ 24	CLR IRQ 23	CLR IRQ 22	CLR IRQ 21	CLR IRQ 20	CLR IRQ 19	CLR IRQ 18	CLR IRQ 17	CLR IRQ 16	
78	AC FAIL IRQ LEVEL			X		ABORT IRQ LEVEL			X			SYS FAIL IRQ LEVEL		X		MST WP ERROR IRQ LEVEL	
7C	VME IACK IRQ LEVEL			X		DMA IRQ LEVEL			X			SIG 3 IRQ LEVEL		X		SIG 2 IRQ LEVEL	
80	SW7 IRQ LEVEL			X		SW6 IRQ LEVEL			X			SW5 IRQ LEVEL		X		SW4 IRQ LEVEL	
84	SPARE IRQ LEVEL			X		VME IRQ 7 IRQ LEVEL			X			VME IRQ 6 IRQ LEVEL		X		VME IRQ 5 IRQ LEVEL	
88	VECTOR BASE REGISTER 0				VECTOR BASE REGISTER 1				MST IRQ EN	SYS FAIL LEVEL	AC FAIL LEVEL	ABORT LEVEL	GPIOEN				
8C	(Crossed out)																

This sheet continues on facing page. →

15	14	13	12	11	10	9	8	7	6	5	4	3	2	1	0
VME ACCESS TIMER		LOCAL BUS TIMER		WD TIME OUT SELECT				PRESCALER CLOCK ADJUST							
COMPARE REGISTER															
COUNTER															
COPARE REGISTER															
COUNTER															
OVERFLOW COUNTER 2				X	CLR OVF 2	COC EN 2	TIC EN 2	OVERFLOW COUNTER 1				X	CLR OVF 1	COC EN 1	TIC EN 1
SCALER															
15	14	13	12	11	10	9	8	7	6	5	4	3	2	1	0
SW7 IRQ	SW6 IRQ	SW5 IRQ	SW4 IRQ	SW3 IRQ	SW2 IRQ	SW1 IRQ	SW0 IRQ	SPARE	VME IRQ7	VME IRQ6	VME IRQ5	VME IRQ4	VME IRQ3	VME IRQ2	VME IRQ1
EN IRQ 15	EN IRQ 14	EN IRQ 13	EN IRQ 12	EN IRQ 11	EN IRQ 10	EN IRQ 9	EN IRQ 8	EN IRQ 7	EN IRQ 6	EN IRQ 5	EN IRQ 4	EN IRQ 3	EN IRQ 2	EN IRQ 1	EN IRQ 0
SET IRQ 15	SET IRQ 14	SET IRQ 13	SET IRQ 12	SET IRQ 11	SET IRQ 10	SET IRQ 9	SET IRQ 8	X							
CLR IRQ 15	CLR IRQ 14	CLR IRQ 13	CLR IRQ 12	CLR IRQ 11	CLR IRQ 10	CLR IRQ 9	CLR IRQ 8								
X		P ERROR IRQ LEVEL		X		IRQ1E IRQ LEVEL		X		TIC TIMER 2 IRQ LEVEL		X		TIC TIMER 1 IRQ LEVEL	
X		SIG 1 IRQ LEVEL		X		SIG 0 IRQ LEVEL		X		LM 1 IRQ LEVEL		X		LM 0 IRQ LEVEL	
X		SW3 IRQ LEVEL		X		SW2 IRQ LEVEL		X		SW1 IRQ LEVEL		X		SW0 IRQ LEVEL	
X		VME IRQ 4 IRQ LEVEL		X		VMEB IRQ 3 IRQ LEVEL		X		VME IRQ 2 IRQ LEVEL		X		VME IRQ 1 IRQ LEVEL	
GPIOO				GPIOI				GPI							
								MP IRQ EN	REV EROM	DIS SRAM	DIS MST	NO EL BBSY	DIS BSYT	EN INT	DIS BGN

1361 9403

← This sheet begins on facing page.

This page intentionally left blank.

Table 3-3. VMEchip2 Memory Map (Sheet 3 of 3)

VMEchip2 GCSR Base Address = \$FFF40100

Offsets		15	14	13	12	11	10	9	8	7	6	5	4	3	2	1	0
VME-bus	Local Bus																
0	0	CHIP REVISION								CHIP ID							
2	4	LM3	LM2	LM1	LM0	SIG3	SIG2	SIG1	SIG0	RST	ISF	BF	SCON	SYSFL	X	X	X
4	8	GENERAL PURPOSE CONTROL AND STATUS REGISTER 0															
6	C	GENERAL PURPOSE CONTROL AND STATUS REGISTER 1															
8	10	GENERAL PURPOSE CONTROL AND STATUS REGISTER 2															
A	14	GENERAL PURPOSE CONTROL AND STATUS REGISTER 3															
C	18	GENERAL PURPOSE CONTROL AND STATUS REGISTER 4															
E	1C	GENERAL PURPOSE CONTROL AND STATUS REGISTER 5															

Table 3-4. PCCchip2 Memory Map

**PCCchip2 Base Address = \$FFF42000
OFFSET:**

	D31					D24					D23					D16				
00	CHIP ID										CHIP REVISION									
04																TIC TIMER 1				
08																TIC TIMER 1				
0C																TIC TIMER 2				
10																TIC TIMER 2				
14	PRESCALER COUNT REGISTER										PRESCALER CLOCK ADJUST									
18	GPI PLTY	GPI E/L*	GPI INT	GPI IEN	GPI ICLR	GPI IRQ LEVEL					X					GPI	GPOE	GPO		
1C	X					SCC RTRY ERR	SCC PAR ERR	SCC EXT ERR	SCC LTO ERR	SCC SCLR	X					SCC MDM ERR	SCC MDM IEN	SCC MDM AVEC	SCC MODEM IRQ LEVEL	
20	X																			
24	X										SCC TRANSMIT PIACK									
28	X					LAN PAR ERR	LAN EXT ERR	LAN LTO ERR	LAN SCLR	X										
2C	X					SCSI PAR ERR	SCSI EXT ERR	SCSI LTO ERR	SCSI SCLR	X										
30	PRTR ACK PLTY	PRTR ACK E/L*	PRTR ACK INT	PRTR ACK IEN	PRTR ACK ICLR	PRTR ACK IRQ LEVEL					PRTR FLT PLTY	PRTR FLT E/L*	PRTR FLT INT	PRTR FLT IEN	PRTR FLT ICLR	PRTR FAULT IRQ LEVEL				
34	PRTR BSY PLTY	PRTR BSY E/L*	PRTR BSY INT	PRTR BSY IEN	PRTR BSY ICLR	PRTR BSY IRQ LEVEL					X									
38	CHIP SPEED																			
3C	X																			

SCC PROVIDES ITS OWN VECTORS

This sheet continues on facing page. →

D15					D8 D7			D0							
DRO		X		X		CPU 040	MSTR INT EN	FAST BRAM	VECTOR BASE REGISTER						
COMPARE REGISTER															
COUNTER REGISTER															
COMPARE REGISTER															
COUNTER REGISTER															
OVERFLOW COUNTER 2				X		CLR OVF 2	COC EN 2	TIC EN 2	OVERFLOW COUNTER 1				X		
X		TIC2 INT	TIC2 IEN	TIC2 ICLR	TIC TIMER 2 IRQ LEVEL			X		TIC1 INT	TIC1 IEN	TIC1 ICLR	TIC TIMER 1 IRQ LEVEL		
X		SCC TX IRQ	SCC TX IEN	SCC TX AVEC	SCC TRANSMIT IRQ LEVEL			SCC SC1	SCC SC0	SCC RX IRQ	SCC RX IEN	SCC RX AVEC	SCC RECEIVE IRQ LEVEL		
X						SCC MODEM PIACK						X			
X						SCC RECEIVE PIACK						X			
LAN INT PLTY	LAN INT E/L*	LAN INT	LAN IEN	LAN ICLR	LAN INT IRQ LEVEL			LAN SC1	LAN SC0	LAN ERR INT	LAN ERR IEN	LAN ERR ICLR	LAN ERR IRQ LEVEL		
X						X		SCSI IRQ	SCSI IEN	X		SCSI INT IRQ LEVEL			
PRTR SEL PLTY	PRTR SEL E/L*	PRTR SEL INT	PRTR SEL IEN	PRTR SEL ICLR	PRTR SEL IRQ LEVEL			PRTR PE PLTY	PRTR PE E/L*	PRTR PE INT	PRTR PE IEN	PRTR PE ICLR	PRTR PE IRQ LEVEL		
PRTR ANY INT	X		PRTR ACK	PRTR FLT	PRTR SEL	PRTR PE	PRTR BSY	X		PRTR DAT ENBL	PRTR INP	PRTR STB	PRTR FAST ASTB	PRTR MAN STB	
PRINTER DATA															
X				X		INTERRUPT IPL LEVEL			X				INTERRUPT MASK LEVEL		

1362 9403

← This sheet begins on facing page.

Table 3-5. Printer Memory Map

Printer ACK Interrupt Control Register **\$FFF42030**

BIT	31	30	29	28	27	26	25	24
NAME	PLTY	E/L*	INT	IEN	ICLR	IL2	IL1	IL0

Printer FAULT Interrupt Control Register **\$FFF42031**

BIT	23	22	21	20	19	18	17	16
NAME	PLTY	E/L*	INT	IEN	ICLR	IL2	IL1	IL0

Printer SEL Interrupt Control Register **\$FFF42032**

BIT	15	14	13	12	11	10	9	8
NAME	PLTY	E/L*	INT	IEN	ICLR	IL2	IL1	IL0

Printer PE Interrupt Control Register **\$FFF42033**

BIT	7	6	5	4	3	2	1	0
NAME	PLTY	E/L*	INT	IEN	ICLR	IL2	IL1	IL0

Printer BUSY Interrupt Control Register **\$FFF42034**

BIT	31	30	29	28	27	26	25	24
NAME	PLTY	E/L*	INT	IEN	ICLR	IL2	IL1	IL0

Printer Input Status Register **\$FFF42036**

BIT	15	14	13	12	11	10	9	8
NAME	PLTY			ACK	FLT	SEL	PE	BSY

Printer Port Control Register **\$FFF42037**

BIT	7	6	5	4	3	2	1	0
NAME				DOEN	INP	STB	FAST	MAN

Printer Data Register 16 bits **\$FFF4203A**

BIT	15-0							
NAME	PD15 - PD0							

Table 3-6. MEMC040 Internal Register Memory Map

2nd MEMC040	1st MEMC040	Data Bits							
		D31	D30	D29	D28	D27	D26	D25	D24
\$FFF43100	\$FFF43000	CID7	CID6	CID5	CID4	CID3	CID2	CID1	CID0
\$FFF43104	\$FFF43004	REV7	REV6	REV5	REV4	REV3	REV2	REV1	REV0
\$FFF43108	\$FFF43008			FSTRD	EXTPEN	WPB*	MSIZ2	MSIZ1	MSIZ0
\$FFF4310C	\$FFF4300C	STS7	STS6	STS5	STS4	STS3	STS2	STS1	STS0
\$FFF43110	\$FFF43010	OUT7	OUT6	OUT5	OUT4	OUT3	OUT2	OUT1	OUT0
\$FFF43114	\$FFF43014	BAD31	BAD30	BAD29	BAD28	BAD27	BAD26	BAD25	BAD24
\$FFF43118	\$FFF43018	BAD23	BAD22	DMCTL	SWAIT	WWP	PARINT	PAREN	RAMEN
\$FFF4311C	\$FFF4301C	BCK7	BCK6	BCK5	BCK4	BCK3	BCK2	BCK1	BCK0

Table 3-7. MCECC Internal Register Memory Map

MCECC Base Address = \$FFF43000 (1st); \$FFF43100 (2nd)

Register Offset	Register Name	Register Bit Names							
		D31	D30	D29	D28	D27	D26	D25	D24
\$00	CHIP ID	CID7	CID5	CID5	CID4	CID3	CID2	CID1	CID0
\$04	CHIP REVISION	REV7	REV6	REV5	REV4	REV3	REV2	REV1	REV0
\$08	MEMORY CONFIG	0	0	FSTRD	1	0	MSIZ2	MSIZ1	MSIZ0
\$0C	DUMMY 0	0	0	0	0	0	0	0	0
\$10	DUMMY 1	0	0	0	0	0	0	0	0
\$14	BASE ADDRESS	BAD31	BAD30	BAD29	BAD28	BAD27	BAD26	BAD25	BAD24
\$18	DRAM CONTROL	BAD23	BAD22	RWB5	SWAIT	RWB3	NCEIEN	NCEBEN	RAMEN
\$1C	BCLK FREQUENCY	BCK7	BCK6	BCK5	BCK4	BCK3	BCK2	BCK1	BCK0

Table 3-7. MCECC Internal Register Memory Map (Continued)

MCECC Base Address = \$FFF43000 (1st); \$FFF43100 (2nd)

Register Offset	Register Name	Register Bit Names							
		D31	D30	D29	D28	D27	D26	D25	D24
\$20	DATA CONTROL	0	0	DERC	ZFILL	RWCKB	0	0	0
\$24	SCRUB CONTROL	RACODE	RADATA	HITDIS	SCRB	SCRBEN	0	SBEIEN	IDIS
\$28	SCRUB PERIOD	SBPD15	SBPD14	SBPD13	SBPD12	SBPD11	SBPD10	SBPD9	SBPD8
\$2C	SCRUB PERIOD	SBPD7	SBPD6	SBPD5	SBPD4	SBPD3	SBPD2	SBPD1	SBPD0
\$30	CHIP PRESCALE	CPS7	CPS6	CPS5	CPS4	CPS3	CPS2	CPS1	CPS0
\$34	SCRUB TIME ON/OFF	SRDIS	0	STON2	STON1	STON0	STOFF2	STOFF1	STOFF0
\$38	SCRUB PRESCALE	0	0	SPS21	SPS20	SPS19	SPS18	SPS17	SPS16
\$3C	SCRUB PRESCALE	SPS15	SPS14	SPS13	SPS12	SPS11	SPS10	SPS9	SPS8
\$40	SCRUB PRESCALE	SPS7	SPS6	SPS5	SPS4	SPS3	SPS2	SPS1	SPS0
\$44	SCRUB TIMER	ST15	ST14	ST3	ST12	ST11	ST10	ST9	ST8
\$48	SCRUB TIMER	ST7	ST6	ST5	ST4	ST3	ST2	ST1	ST0
\$4C	SCRUB ADDR CNTR	0	0	0	0	0	SAC26	SAC25	SAC24
\$50	SCRUB ADDR CNTR	SAC23	SAC22	SAC21	SAC20	SAC19	SAC18	SAC17	SAC16
\$54	SCRUB ADDR CNTR	SAC15	SAC14	SAC13	SAC12	SAC11	SAC10	SAC9	SAC8
\$58	SCRUB ADDR CNTR	SAC7	SAC6	SAC5	SAC4	0	0	0	0
\$5C	ERROR LOGGER	ERRLOG	ERD	ESCRB	ERA	EALT	0	MBE	SBE
\$60	ERROR ADDRESS	EA31	EA30E	EA29	EA28	EA27	EA26	EA25	EA24
\$64	ERROR ADDRESS	EA23	EA22	EA21	EA20	EA19	EA18	EA17	EA16
\$68	ERROR ADDRESS	EA15	EA14	EA13	EA12	EA11	EA10	EA9	EA8
\$6C	ERROR ADDRESS	EA7	EA6	EA5	EA4	0	0	0	0
\$70	ERROR SYNDROME	S7	S6	S5	S4	S3	S2	S1	S0
\$74	DEFAULTS1	WRHDIS	STATCOL	FSTRD	SELI1	SELI0	RSIZ2	RSIZ1	RSIZ0
\$78	DEFAULTS2	FRC_OPN	XY_FLIP	REFDIS	TVECT	NOCACHE	RESST2	RESST1	RESST0

Table 3-8. Cirrus Logic CD2401 Serial Port Memory Map**Base Address = \$FFF45000**

Register Description	Register Name	Offsets	Size	Access
Global Registers				
Global Firmware Revision Code Register	GFRCR	81	B	R
Channel Access Register	CAR	EE	B	R/W
Option Registers				
Channel Mode Register	CMR	1B	B	R/W
Channel Option Register 1	COR1	10	B	R/W
Channel Option Register 2	COR2	17	B	R/W
Channel Option Register 3	COR3	16	B	R/W
Channel Option Register 4	COR4	15	B	R/W
Channel Option Register 5	COR5	14	B	R/W
Channel Option Register 6	COR6	18	B	R/W
Channel Option Register 7	COR7	07	B	R/W
Special Character Register 1	SCHR1	1F	B	R/W Async
Special Character Register 2	SCHR2	1E	B	R/W Async
Special Character Register 3	SCHR3	1D	B	R/W Async
Special Character Register 4	SCHR4	1C	B	R/W Async
Special Character Range low	SCRl	23	B	R/W Async
Special Character Range high	SCRh	22	B	R/W Async
LNext Character	LNXT	2E	B	R/W Async
Bit Rate and Clock Option Registers				
Receive Frame Address Register1	RFAR1	1F	B	R/W Sync
Receive Frame Address Register2	RFAR2	1E	B	R/W Sync
Receive Frame Address Register3	RFAR3	1D	B	R/W Sync
Receive Frame Address Register4	RFAR4	1C	B	R/W Sync
CRC Polynomial Select Register	CPSR	D6	B	R/W Sync
Receive Baud Rate Period Register	RBPR	CB	B	R/W
Receive Clock Option Register	RCOR	C8	B	R/W
Transmit Baud Rate Period Register	TBPR	C3	B	R/W
Transmit Clock Option Register	TCOR	C0	B	R/W

Table 3-8. Cirrus Logic CD2401 Serial Port Memory Map (Continued)

Base Address = \$FFF45000

Register Description	Register Name	Offsets	Size	Access
Channel Command and Status Registers				
Channel Command Register	CCR	13	B	R/W
Special Transmit Command Register	STCR	12	B	R/W
Channel Status Register	CSR	1A	B	R
Modem Signal Value Registers	MSVR-RTS	DE	B	R/W
	MSVR-DTR	DF	B	R/W
Interrupt Registers				
Local Interrupt Vector Register	LIVR	09	B	R/W
Interrupt Enable Register	IER	11	B	R/W
Local Interrupting Channel Register	LICR	26	B	R/W
Stack Register	STK	E2	B	R
Receive Interrupt Registers				
Receive Priority Interrupt Level Register	RPILR	E1	B	R/W
Receive Interrupt Register	RIR	ED	B	R
Receive Interrupt Status Register	RISR	88	W (NOTE)	R/W
Receive Interrupt Status Register low	RISRl	89	B	R
Receive Interrupt Status Register high	RISRh	88	B	R
Receive FIFO Output Count	RFOC	30	B	R
Receive Data Register	RDR	F8	B	R
Receive End Of Interrupt Register	REOIR	84	B	W
Transmit Interrupt Registers				
Transmit Priority Interrupt Level Register	TPILR	E0	B	R/W
Transmit Interrupt Register	TIR	EC	B	R
Transmit Interrupt Status Register	TISR	8A	B	R
Transmit FIFO Transfer Count	TFTC	80	B	R
Transmit Data Register	TDR	F8	B	W
Transmit End Of Interrupt Register	TEOIR	85	B	W

Table 3-8. Cirrus Logic CD2401 Serial Port Memory Map (Continued)

Base Address = \$FFF45000

Register Description	Register Name	Offsets	Size	Access
Modem Interrupt Registers				
Modem Priority Interrupt Level Register	MPILR	E3	B	R/W
Modem Interrupt Register	MIR	EF	B	R
Modem (/Timer) Interrupt Status Register	MISR	8B	B	R
Modem End Of Interrupt Register	MEOIR	86	B	W
DMA Registers				
DMA Mode Register (write only)	DMR	F6	B	W
Bus Error Retry Count	BERCNT	8E	B	R/W
DMA Buffer Status	DMABSTS	19	B	R
DMA Receive Registers				
A Receive Buffer Address Lower	ARBADRL	42	W	R/W
A Receive Buffer Address Upper	ARBADRU	40	W	R/W
B Receive Buffer Address Lower	BRBADRL	46	W	R/W
B Receive Buffer Address Upper	BRBADRU	44	W	R/W
A Receive Buffer Byte Count	ARBCNT	4A	W	R/W
B Receive Buffer Byte Count	BRBCNT	48	W	R/W
A Receive Buffer Status	ARBSTS	4F	B	R/W
B Receive Buffer Status	BRBSTS	4E	B	R/W
Receive Current Buffer Address Lower	RCBADRL	3E	W	R
Receive Current Buffer Address Upper	RCBADRU	3C	W	R
DMA Transmit Registers				
A Transmit Buffer Address Lower	ATBADRL	52	W	R/W
A Transmit Buffer Address Upper	ATBADRU	50	W	R/W
B Transmit Buffer Address Lower	BTBADRL	56	W	R/W
B Transmit Buffer Address Upper	BTBADRU	54	W	R/W
A Transmit Buffer Byte Count	ATBCNT	5A	W	R/W
B Transmit Buffer Byte Count	BTBCNT	58	W	R/W
A Transmit Buffer Status	ATBSTS	5F	B	R/W
B Transmit Buffer Status	BTBSTS	5E	B	R/W
Transmit Current Buffer Address Lower	TCBADRL	3A	W	R
Transmit Current Buffer Address Upper	TCBADRU	38	W	R

Table 3-8. Cirrus Logic CD2401 Serial Port Memory Map (Continued)

Base Address = \$FFF45000

Register Description	Register Name	Offsets	Size	Access
Timer Registers				
Timer Period Register	TPR	DA	B	R/W
Receive Time-out Period Register	RTPR	24	W	R/W Async
Receive Time-out Period Regis low	RTPRI	25	B	R/W Async
Receive Time-out Period Register high	RTPRh	24	B	R/W Async
General Timer 1	GT1	2A	W	R Sync
General Timer 1 low	GT1l	2B	B	R Sync
General Timer 1 high	GT1h	2A	B	R Sync
General Timer 2	GT2	29	B	R Sync
Transmit Timer Register	TTR	29	B	R Async

NOTE: This is a 16-bit register.

Table 3-9. 82596CA Ethernet LAN Memory Map
82596CA Ethernet LAN Directly Accessible Registers

Address	Data Bits			
	D31	D16	D15	D0
\$FFF46000	Upper Command Word		Lower Command Word	
\$FFF46004	MPU Channel Attention (CA)			

- NOTES:**
1. Refer to the MPU Port and MPU Channel Attention registers in the *MVME166/MVME167/MVME187 Single Board Computers Programmer's Reference Guide*.
 2. After resetting, you must write the System Configuration Pointer to the command registers before writing to the MPU Channel Attention register. Writes to the System Configuration Pointer must be upper word first, lower word second.

Table 3-10. 53C710 SCSI Memory Map

53C710 Register Address Map			Base Address is \$FFF47000		
Big Endian Mode					SCRIPTs Mode and Little Endian Mode
00	SIEN	SDID	SCNTL1	SCNTL0	00
04	SOCL	SODL	SXFER	SCID	04
08	SBCL	SBDL	SIDL	SFBR	08
0C	SSTAT2	SSTAT1	SSTAT0	DSTAT	0C
10	DSA				10
14	CTEST3	CTEST2	CTEST1	CTEST0	14
18	CTEST7	CTEST6	CTEST5	CTEST4	18
1C	TEMP				1C
20	LCRC	CTEST8	ISTAT	DFIFO	20
24	DCMD	DBC			24
28	DNAD				28
2C	DSP				2C
30	DSPS				30
34	SCRATCH				34
38	DCNTL	DWT	DIEN	DMODE	38
3C	ADDER				3C

NOTE: Accesses may be 8-bit or 32-bit, but not 16-bit.

Table 3-11. MK48T08 BBRAM,TOD Clock Memory Map

Address Range	Description	Size (Bytes)
\$FFFC0000 - \$FFFC0FFF	User Area	4096
\$FFFC1000 - \$FFFC10FF	Networking Area	256
\$FFFC1100 - \$FFFC16F7	Operating System Area	1528
\$FFFC16F8 - \$FFFC1EF7	Debugger Area	2048
\$FFFC1EF8 - \$FFFC1FF7	Configuration Area	256
\$FFFC1FF8 - \$FFFC1FFF	TOD Clock	8

Table 3-12. BBRAM Configuration Area Memory Map

Address Range	Description	Size (Bytes)
\$FFFC1EF8 - \$FFFC1EFB	Version	4
\$FFFC1EFC - \$FFFC1F07	Serial Number	12
\$FFFC1F08 - \$FFFC1F17	Board ID	16
\$FFFC1F18 - \$FFFC1F27	PWA	16
\$FFFC1F28 - \$FFFC1F2B	Speed	4
\$FFFC1F2C - \$FFFC1F31	Ethernet Address	6
\$FFFC1F32 - \$FFFC1F33	Reserved	2
\$FFFC1F34 - \$FFFC1F35	SCSI ID	2
\$FFFC1F36 - \$FFFC1F3D	System ID	8
\$FFFC1F3E - \$FFFC1F45	Mezz. Board 1 PWB	8
\$FFFC1F46 - \$FFFC1F4D	Mezz. Board 1 Serial Number	8
\$FFFC1F4E - \$FFFC1F55	Mezz. Board 2 PWB	8
\$FFFC1F56 - \$FFFC1F5D	Mezz. Board 2 Serial Number	8
\$FFFC1F5E - \$FFFC1FF6	Reserved	153
\$FFFC1FF7	Checksum	1

Table 3-13. TOD Clock Memory Map

Address	Data Bits								Function	
	D7	D6	D5	D4	D3	D2	D1	D0		
\$FFFC1FF8	W	R	S	--	--	--	--	--	CONTROL	00
\$FFFC1FF9	ST	--	--	--	--	--	--	--	SECONDS	00
\$FFFC1FFA	x	--	--	--	--	--	--	--	MINUTES	00
\$FFFC1FFB	x	x	--	--	--	--	--	--	HOUR	00
\$FFFC1FFC	x	FT	x	x	x	--	--	--	DAY	01
\$FFFC1FFD	x	x	--	--	--	--	--	--	DATE	01
\$FFFC1FFE	x	x	x	--	--	--	--	--	MONTH	01
\$FFFC1FFF	--	--	--	--	--	--	--	--	YEAR	00

NOTES: W = Write Bit R = Read Bit S = Signbit
 ST = Stop Bit FT = Frequency Test x = Unused

BBRAM, TOD Clock Memory Map

The MK48T08 BBRAM (also called Non-Volatile RAM or NVRAM) is divided into six areas as shown in Table 3-11. *MK48T08 BBRAM, TOD Clock Memory Map* on page 3-25. The first five areas are defined by software, while the sixth area, the time-of-day (TOD) clock, is defined by the chip hardware. The first area is reserved for user data. The second area is used by Motorola networking software. The third area is used by the SYSTEM V/68 operating system. The fourth area is used by the MVME167 board debugger (MVME167Bug). The fifth area, detailed in Table 3-12. *BBRAM Configuration Area Memory Map* on page 3-25, is the configuration area. The sixth area, the TOD clock, detailed in Table 3-13. *TOD Clock Memory Map* on page 3-26, is defined by the chip hardware.

The data structure of the configuration bytes starts at \$FFFC1EF8 and is as follows.

```

struct brdi_cnfg {
    char    version[4];
    char    serial[12];
    char    id[16];
    char    pwa[16];
    char    speed[4];
    char    ethernet_adr[6];
    char    fill[2];
    char    lscsiid[2];
    char    sysid[8];
    char    brd1_pwb[8];
    char    brd1_serial[8];
}
    
```

```

char        brd2_pwb[8];
char        brd2_serial[8];
char        reserved[153];
char        cksum[1];
}

```

The fields are defined as follows:

1. Four bytes are reserved for the revision or version of this structure. This revision is stored in ASCII format, with the first two bytes being the major version numbers and the last two bytes being the minor version numbers. For example, if the version of this structure is 1.0, this field contains:

0100

2. Twelve bytes are reserved for the serial number of the board in ASCII format. For example, this field could contain:

000000470476

3. Sixteen bytes are reserved for the board ID in ASCII format. For example, for a 16 MB, 25 MHz MVME167 board, this field contains:

MVME167-003B

(The 12 characters are followed by four blanks.)

4. Sixteen bytes are reserved for the printed wiring assembly (PWA) number assigned to this board in ASCII format. This includes the 01-w prefix. This is for the main logic board if more than one board is required for a set. Additional boards in a set are defined by a structure for that set. For example, for a 16 MB, 25 MHz MVME167 board at revision A, the PWA field contains:

01-W3899B03A

(The 12 characters are followed by four blanks.)

5. Four bytes contain the speed of the board in MHz. The first two bytes are the whole number of MHz and the second two bytes are fractions of MHz. For example, for a 25.00 MHz board, this field contains:

2500

6. Six bytes are reserved for the Ethernet address. The address is stored in hexadecimal format. (Refer to the detailed description in *Chapter 4*.) If the board does not support Ethernet, this field is filled with zeros.
7. These two bytes are reserved.
8. Two bytes are reserved for the local SCSI ID. The SCSI ID is stored in ASCII format.
9. Eight bytes are reserved for the systems serial ID, for boards 1used in a system.

10. Eight bytes are reserved for the printed wiring board (PWB) number assigned to the first mezzanine board in ASCII format. This does *not* include the 01-w prefix. For example, for a 16MB parity mezzanine at revision E, the PWB field contains:

3690B03E

11. Eight bytes are reserved for the serial number assigned to the first mezzanine board in ASCII format.
12. Eight bytes are reserved for the printed wiring board (PWB) number assigned to the optional second mezzanine board in ASCII format.
13. Eight bytes are reserved for the serial number assigned to the optional second mezzanine board in ASCII format.
14. Growth space (153 bytes) is reserved. This pads the structure to an even 256 bytes. System-specific items, such as size of system side, and systems side version, may go here.
15. The final one byte of the area is reserved for a checksum (as defined in the *MVME167Bug Debugging Package User's Manual* and the *Debugging Package for Motorola 68K CISC CPUs User's Manual*) for security and data integrity of the configuration area of the NVRAM. This data is stored in hexadecimal format.

Interrupt Acknowledge Map

The local bus distinguishes interrupt acknowledge cycles from other cycles by placing the binary value %11 on TT1-TT0. It also specifies the level that is being acknowledged using TM2-TM0. The interrupt handler selects which device within that level is being acknowledged.

On the MVME187, a read anywhere from location \$FFFE0004 through \$FFFE001C causes an interrupt acknowledge cycle at the specified level. This does not do so on the MVME167. Refer to the PCCchip2 information in the *MVME166/MVME167/MVME187 Single Board Computers Programmer's Reference Guide* for information on reading the current interrupt level and setting the interrupt mask.

VMEbus Memory Map

This section describes the mapping of local resources as viewed by VMEbus masters.

VMEbus Accesses to the Local Bus

The VMEchip2 includes a user-programmable map decoder for the VMEbus to local bus interface. The map decoder allows you to program the starting and ending address and the modifiers the MVME167 responds to.

VMEbus Short I/O Memory Map

The VMEchip2 includes a user-programmable map decoder for the GCSR. The GCSR map decoder allows you to program the starting address of the GCSR in the VMEbus short I/O space.

Software Initialization

Most functions that have been done with switches or jumpers on other modules are done by setting control registers on the MVME167. At powerup or reset, the EPROMs that contain the 167Bug debugging package set up the default values of many of these registers.

Specific programming details may be determined by study of the *MC68040 Microprocessor User's Manual*. Then check the details of all the MVME167 onboard registers as given in the *MVME166/MVME167/MVME187 Single Board Computers Programmer's Reference Guide*.

Multi-MPU Programming Considerations

Good programming practice dictates that only one MPU at a time have control of the MVME167 control registers.

Of particular note are:

- registers that modify the address map;
- registers that require two cycles to access; and
- VMEbus interrupt request registers.

Local Reset Operation

Local reset (LRST) is a subset of system reset (SRST). Local reset can be generated five ways: expiration of the watchdog timer, pressing the front panel RESET switch (if the system controller function is disabled), by asserting a bit in the board control register in the GCSR, by SYSRESET*, or by powerup reset.

Note

The GCSR allows a VMEbus master to reset the local bus. This feature is very dangerous and should be used with caution. The local reset feature is a partial system reset, not a complete system reset such as powerup reset or SYSRESET*. When the local bus reset signal is asserted, a local bus cycle may be aborted. The VMEchip2 is connected to both the local bus and the VMEbus and if the aborted cycle is bound for the VMEbus, erratic operation may result. Communications between the local processor and a VMEbus master should use interrupts or mailbox locations; reset should not be used in normal communications. Reset should be used only when the local processor is halted or the local bus is hung and reset is the last resort.

Any VMEbus access to the MVME167 while it is in the reset state is ignored. If a global bus timer is enabled, a bus error is generated.

Introduction

This chapter provides a block diagram level description for the MVME167 module. The functional description provides an overview of the module, followed by a detailed description of several blocks of the module. The block diagram of the MVME167 is shown in Figure 4-1. *MVME167 Main Module Block Diagram* on page 4-10. The block diagram of the parity DRAM mezzanine module of the MVME167 is shown as Figure 4-2. *Parity DRAM Mezzanine Module Block Diagram* on page 4-11. The block diagram of the ECC DRAM mezzanine module of the MVME167 is shown as Figure 4-2. *Parity DRAM Mezzanine Module Block Diagram* on page 4-11.

Descriptions of the other blocks of the MVME167, including programmable registers in the ASICs and peripheral chips, are given in the *MVME166/MVME167/MVME187 Single Board Computers Programmer's Reference Guide*. Refer to it for the rest of the functional description of the MVME167 module.

MVME167 Functional Description

The MVME167 is a high functionality VMEbus single board computer designed around the MC68040 chip. It has 4/8/16/32/64/128/256MB of dynamic RAM, a SCSI mass storage interface, four serial ports, a printer port, and an Ethernet transceiver interface.

Data Bus Structure

The local data bus on the MVME167 is a 32-bit synchronous bus that is based on the MC68040 bus, and supports burst transfers and snooping. The various local bus master and slave devices use the local bus to communicate. The local bus is arbitrated by priority type arbiter and the priority of the local bus masters from highest to lowest is: 82596CA LAN, CD2401 serial (through the PCCchip2), 53C710 SCSI, VMEbus, and MPU. In the general case, any master can access any slave; however, not all combinations pass the common sense test. Refer to the *MVME166/MVME167/MVME187 Single Board Computers Programmer's Reference Guide* and to the user's guide for each device to determine its port size, data bus connection, and any restrictions that apply when accessing the device.

MC68040 MPU

The MC68040 processor is used on the MVME167. The MC68040 has on-chip instruction and data caches and a floating point processor. Refer to the MC68040 user's manual for more information.

EPROM

There are four 44-pin PLCC/CLCC EPROM sockets for 27C102JK or 27C202JK type EPROMs. They are organized as two 32-bit wide banks that support 8-, 16-, and 32-bit read accesses. The EPROMs are mapped to local bus address 0 following a local bus reset. This allows the MC68040 to access the stack pointer and execution address following a reset. The EPROMs are controlled by the VMEchip2. The map decoder, access time, and when they appear at address 0 is programmable. For more detail, refer to the VMEchip2 in the *MVME166/MVME167/MVME187 Single Board Computers Programmer's Reference Guide*.

SRAM

The boards include 128KB of 32-bit wide static RAM that supports 8-, 16-, and 32-bit wide accesses. The SRAM allows the debugger to operate and limited diagnostics to be executed without the DRAM mezzanine. The SRAM is controlled by the VMEchip2, and the access time is programmable. Refer to the VMEchip2 in the *MVME166/MVME167/MVME187 Single Board Computers Programmer's Reference Guide* for more detail. The boards are populated with 100 ns SRAMs.

SRAM battery backup is optionally available on the MVME167. The battery backup function is provided by a Dallas DS1210S. Only one backup power source is supported on the MVME167.

Each time the MVME167 is powered, the DS1210S checks power source and if the voltage of the backup source is less than two volts, the second memory cycle is blocked. This allows software to provide an early warning to avoid data loss. Because the DS1210S may block the second access, the software should do at least two accesses before relying on the data.

Optionally, the MVME167 provides jumpers that allow the power source of the DS1210S to be connected to the VMEbus +5 V STDBY pin or the onboard battery.

The optional power source SRAM is a socketed Sanyo CR2430 battery. A small capacitor is provided to allow the battery to be quickly replaced without data loss.

The lifetime of the battery is very dependent on the ambient temperature of the board and the power-on duty cycle. The FB1225 and CR2430 lithium batteries should provide at least two years of backup time with the board powered off and the board at

40° C. If the power-on duty cycle is 50% (the board is powered on half of the time), the battery lifetime is four years. At lower ambient temperatures the backup time is greatly extended and may approach the shelf life of the battery.

When a board is stored, if the battery is present, it should be disconnected to prolong battery life. This is especially important at high ambient temperatures. MVME167 boards with battery backup are shipped with the batteries disconnected.

The power leads from the battery are exposed on the solder side of the board, therefore the board should not be placed on a conductive surface or stored in a conductive bag unless the battery is removed.



Lithium batteries incorporate flammable materials such as lithium and organic solvents. If lithium batteries are mistreated or handled incorrectly, they may burst open and ignite, possibly resulting in injury and/or fire. When dealing with lithium batteries, carefully follow the precautions listed below in order to prevent accidents.

- Do not short circuit.
- Do not disassemble, deform, or apply excessive pressure.
- Do not heat or incinerate.
- Do not apply solder directly.
- Do not use different models, or new and old batteries together.
- Do not charge.
- Always check proper polarity.

To remove the battery from the module, carefully pull the battery from the socket.

Onboard DRAM

The MVME167 onboard DRAM is located on a mezzanine board. The mezzanine boards are available in different sizes and with parity protection or ECC protection. Mezzanine board sizes are 4, 8, 16, or 32MB (parity), or 4, 8, 16, 32, 64, or 128MB (ECC); two mezzanine boards may be stacked to provide 256MB of onboard RAM. The main board and a single mezzanine board together take one slot. The stacked configuration requires two VMEboard slots. Motorola software *does* support mixed parity and ECC memory boards on the same main board. The DRAM is four-way interleaved to efficiently support cache burst cycles. The parity mezzanines are only supported on 25 MHz main boards.

The DRAM map decoder can be programmed to accommodate different base address(es) and sizes of mezzanine boards. The onboard DRAM is disabled by a local bus reset and must be programmed before the DRAM can be accessed. Refer to the MEMC040 or the MCECC in the *MVME166/MVME167/MVME187 Single Board Computers Programmer's Reference Guide* for detailed programming information. Most DRAM devices require some number of access cycles before the DRAMs are fully operational. Normally this requirement is met by the onboard refresh circuitry and normal DRAM initialization. However, software should insure a minimum of 10 initialization cycles are performed to each bank of RAM.

Battery Backed Up RAM and Clock

The MK48T08 RAM and clock chip is used on the MVME167. This chip provides a time of day clock, oscillator, crystal, power fail detection, memory write protection, 8KB of RAM, and a battery in one 28-pin package. The clock provides seconds, minutes, hours, day, date, month, and year in BCD 24-hour format. Corrections for 28-, 29- (leap year), and 30-day months are automatically made. No interrupts are generated by the clock. The MK48T08 is an 8 bit device; however, the interface provided by the PCCchip2 supports 8-, 16-, and 32-bit accesses to the MK48T08. Refer to the PCCchip2 in the *MVME166/MVME167/MVME187 Single Board Computers Programmer's Reference Guide* and to the MK48T08 data sheet for detailed programming information.

VMEbus Interface

The local bus to VMEbus interface, the VMEbus to local bus interface, and the local-VMEbus DMA controller functions on the MVME167 are provided by the VMEchip2. The VMEchip2 can also provide the VMEbus system controller functions. Refer to the VMEchip2 in the *MVME166/MVME167/MVME187 Single Board Computers Programmer's Reference Guide* for detailed programming information.

I/O Interfaces

The MVME167 provides onboard I/O for many system applications. The I/O functions include serial ports, printer port, Ethernet transceiver interface, and SCSI mass storage interface.

Serial Port Interface

The CD2401 serial controller chip (SCC) is used to implement the four serial ports. The serial ports support the standard baud rates (110 to 38.4K baud). The four serial ports are different functionally because of the limited number of pins on the P2 I/O connector. Serial port 1 is a minimum function asynchronous port. It uses RXD, CTS, TXD, and RTS. Serial ports 2 and 3 are full function asynchronous ports. They use RXD, CTS, DCD, TXD, RTS, and DTR. Serial port 4 is a full function asynchronous

or synchronous port. It can operate at synchronous bit rates up to 64 k bits per second. It uses RXD, CTS, DCD, TXD, RTS, and DTR. It also interfaces to the synchronous clock signal lines. Refer to the *MVME166/MVME167/MVME187 Single Board Computers Programmer's Reference Guide* for drawings of the serial port interface connections.

All four serial ports use EIA-232-D drivers and receivers located on the main board, and all the signal lines are routed to the I/O connector. The configuration headers are located on the main board and the MVME712X transition board. An external I/O transition board such as the MVME712X should be used to convert the I/O connector pinout to industry-standard connectors.

Note The MVME167 board hardware ties the DTR signal from the CD2401 to the pin labeled RTS at connector P2. Likewise, RTS from the CD2401 is tied to DTR on P2. Therefore, when programming the CD2401, assert DTR when you want RTS, and RTS when you want DTR.

The interface provided by the PCCchip2 allows the 16-bit CD2401 to appear at contiguous addresses; however, accesses to the CD2401 must be 8 or 16 bits. 32-bit accesses are not permitted. Refer to the CD2401 data sheet and to the PCCchip2 in the *MVME166/MVME167/MVME187 Single Board Computers Programmer's Reference Guide* for detailed programming information.

The CD2401 supports DMA operations to local memory. Because the CD2401 does not support a retry operation necessary to break VMEbus lockup conditions, the CD2401 DMA controllers should not be programmed to access the VMEbus. The hardware does not restrict the CD2401 to onboard DRAM.

Parallel Port Interface

The PCCchip2 provides an 8-bit bidirectional parallel port. All eight bits of the port must be either inputs or outputs (no individual selection). In addition to the 8 bits of data, there are two control pins and five status pins. Each of the status pins can generate an interrupt to the MPU in any of the following programmable conditions: high level, low level, high-to-low transition, or low-to-high transition. This port may be used as a Centronics-compatible parallel printer port or as a general parallel I/O port.

When used as a parallel printer port, the five status pins function as: Printer Acknowledge (ACK), Printer Fault (FAULT*), Printer Busy (BSY), Printer Select (SELECT), and Printer Paper Error (PE); while the control pins act as Printer Strobe (STROBE*), and Input Prime (INP*).

The PCCchip2 provides an auto-strobe feature similar to that of the MVME147 PCC. In auto-strobe mode, after a write to the Printer Data Register, the PCCchip2 automatically asserts the STROBE* pin for a selected time specified by the Printer Fast Strobe control bit. In manual mode, the Printer Strobe control bit directly controls the state of the STROBE* pin.

Refer to the *MVME166/MVME167/MVME187 Single Board Computers Programmer's Reference Guide* for drawings of the printer port interface connections.

Ethernet Interface

The 82596CA is used to implement the Ethernet transceiver interface. The 82596CA accesses local RAM using DMA operations to perform its normal functions. Because the 82596CA has small internal buffers and the VMEbus has an undefined latency period, buffer overrun may occur if the DMA is programmed to access the VMEbus. Therefore, the 82596CA should not be programmed to access the VMEbus.

Every MVME167 is assigned an Ethernet Station Address. The address is \$08003E2XXXXX where XXXXX is the unique 5-nibble number assigned to the board (i.e., every MVME167 has a different value for XXXXX).

Each module has an Ethernet Station Address displayed on a label attached to the VMEbus P2 connector. In addition, the six bytes including the Ethernet address are stored in the configuration area of the BBRAM. That is, 08003E2XXXXX is stored in the BBRAM. At an address of \$FFFC1F2C, the upper four bytes (08003E2X) can be read. At an address of \$FFFC1F30, the lower two bytes (XXXX) can be read. Refer to the BBRAM, TOD Clock memory map description in *Chapter 3*. The MVME167 debugger has the capability to retrieve or set the Ethernet address.

If the data in the BBRAM is lost, the user should use the number on the VMEbus P2 connector label to restore it.

The Ethernet transceiver interface is located on the MVME167 main module, and the industry standard connector is located on the MVME712X transition module.

Support functions for the 82596CA are provided by the PCCchip2. Refer to the 82596CA user's guide and to the *MVME166/MVME167/MVME187 Single Board Computers Programmer's Reference Guide* for detailed programming information.

SCSI Interface

The MVME167 provides for mass storage subsystems through the industry-standard SCSI bus. These subsystems may include hard and floppy disk drives, streaming tape drives, and other mass storage devices. The SCSI interface is implemented using the NCR 53C710 SCSI I/O controller.

Support functions for the 53C710 are provided by the PCCchip2. Refer to the 53C710 user's guide and to the *MVME166/MVME167/MVME187 Single Board Computers Programmer's Reference Guide* for detailed programming information.

SCSI Termination

The system configurer must ensure that the SCSI bus is properly terminated at both ends. On the MVME167, sockets are provided for the terminators on the P2 transition board. If the SCSI bus ends at the P2 transition board, then termination resistors must be installed on the P2 transition board. +5V power to the SCSI bus TERM power line and termination resistors is provided through a fuse located on the P2 transition board.

Local Resources

The MVME167 includes many resources for the local processor. These include tick timers, software programmable hardware interrupts, watchdog timer, and local bus timeout.

Programmable Tick Timers

Four 32-bit programmable tick timers with 1 μ s resolution are provided, two in the VMEchip2 and two in the PCCchip2. The tick timers can be programmed to generate periodic interrupts to the processor. Refer to the VMEchip2 and PCCchip2 in the *MVME166/MVME167/MVME187 Single Board Computers Programmer's Reference Guide* for detailed programming information.

Watchdog Timer

A watchdog timer function is provided in the VMEchip2. When the watchdog timer is enabled, it must be reset by software within the programmed time or it times out. The watchdog timer can be programmed to generate a SYSRESET signal, local reset signal, or board fail signal if it times out. Refer to the VMEchip2 in the *MVME166/MVME167/MVME187 Single Board Computers Programmer's Reference Guide* for detailed programming information.

Software-Programmable Hardware Interrupts

Eight software-programmable hardware interrupts are provided by the VMEchip2. These interrupts allow software to create a hardware interrupt. Refer to the VMEchip2 in the *MVME166/MVME167/MVME187 Single Board Computers Programmer's Reference Guide* for detailed programming information.

Local Bus Timeout

The MVME167 provides a timeout function for the local bus. When the timer is enabled and a local bus access times out, a Transfer Error Acknowledge (TEA) signal is sent to the local bus master. The timeout value is selectable by software for 8 μ sec, 64 μ sec, 256 μ sec, or infinite. The local bus timer does not operate during VMEbus

bound cycles. VMEbus bound cycles are timed by the VMEbus access timer and the VMEbus global timer. Refer to the VMEchip2 in the *MVME166/MVME167/MVME187 Single Board Computers Programmer's Reference Guide* for detailed programming information.

Timing Performance

4

This section provides the performance information for the MVME167. Various MVME167s are designed to operate at 25 MHz or 33 MHz.

Local Bus to DRAM Cycle Times

The PCCchip2 and VMEchip2 have the same local bus interface timing as the MC68040, therefore the following cycle times also apply to the PCCchip2 and the VMEchip2. Read accesses to onboard DRAM require 4 bus clock cycles with parity checking off. With parity checking on and the bus error reported in the current cycle, 5 bus clock cycles are required. Write accesses to onboard DRAM require 2 bus clock cycles.

Burst read accesses require 7 (4-1-1-1) bus clock cycles with parity check off. With parity checking on and the bus error reported in the current cycle, 8 (5-1-1-1) bus clock cycles are required. Burst write cycles require 5 (2-1-1-1) bus clock cycles.

The parity DRAM is organized as four banks; this requires the use of 256K by 4 chips for the data portion of the RAM and 256K by 4 chips with the write-per-bit option for the parity bits. The use of four banks allows X-1-1-1 bursts with parity on.

ROM Cycle Times

The ROM cycle time is programmable from 4 to 11 bus clock cycles. The data transfers are 32 bits wide. Refer to the *MVME166/MVME167/MVME187 Single Board Computers Programmer's Reference Guide*.

SCSI Transfers

The MVME167 includes a SCSI mass storage bus interface with DMA controller. The SCSI DMA controller uses a FIFO buffer to interface the 8-bit SCSI bus to the 32-bit local bus. The FIFO buffer allows the SCSI DMA controller to efficiently transfer data to the local bus in four longword bursts. This reduces local bus usage by the SCSI device.

The first longword transfer of a burst, with snooping disabled, takes four bus clocks with parity off and five bus clocks with parity on. Each of the remaining three transfers requires one bus clock.

The transfer rate of the DMA controller is 44 MB/sec at 25 MHz with parity off. Assuming a continuous transfer rate of 5 MB/sec on the SCSI bus, 12% of the local bus bandwidth is used by transfers from the SCSI bus.

LAN DMA Transfers

The MVME167 includes a LAN interface with DMA controller. The LAN DMA controller uses a FIFO buffer to interface the serial LAN bus to the 32-bit local bus. The FIFO buffer allows the LAN DMA controller to efficiently transfer data to the local bus.

The 82596CA does not execute MC68040 compatible burst cycles, therefore the LAN DMA controller does not use burst transfers. Parity DRAM write cycles require 3 clock cycles, and read cycles require 5 clock cycles with parity off and 6 clock cycles with parity on.

The transfer rate of the LAN DMA controller is 20 MB/sec at 25 MHz with parity off. Assuming a continuous transfer rate of 1 MB/sec on the LAN bus, 5% of the local bus bandwidth is used by transfers from the LAN bus.

Remote Status and Control

The remote status and control connector, J3, is a 20-pin connector located behind the front panel of the MVME167. It provides system designers the flexibility to access critical indicator and reset functions. This allows a system designer to construct a RESET/LED panel that can be located remotely from the MVME167.

In addition to the LED and RESET switch access, this connector also includes two general purpose TTL-level I/O pins and one general purpose interrupt pin which can also function as a trigger input. This interrupt pin is level programmable.

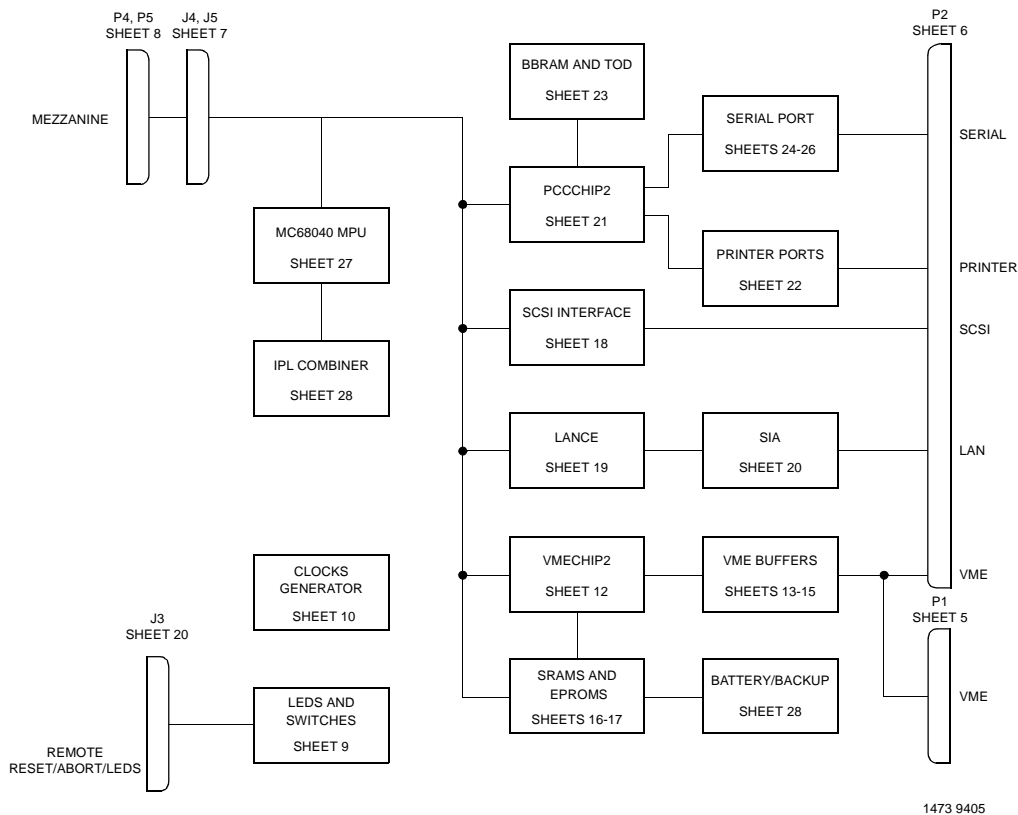
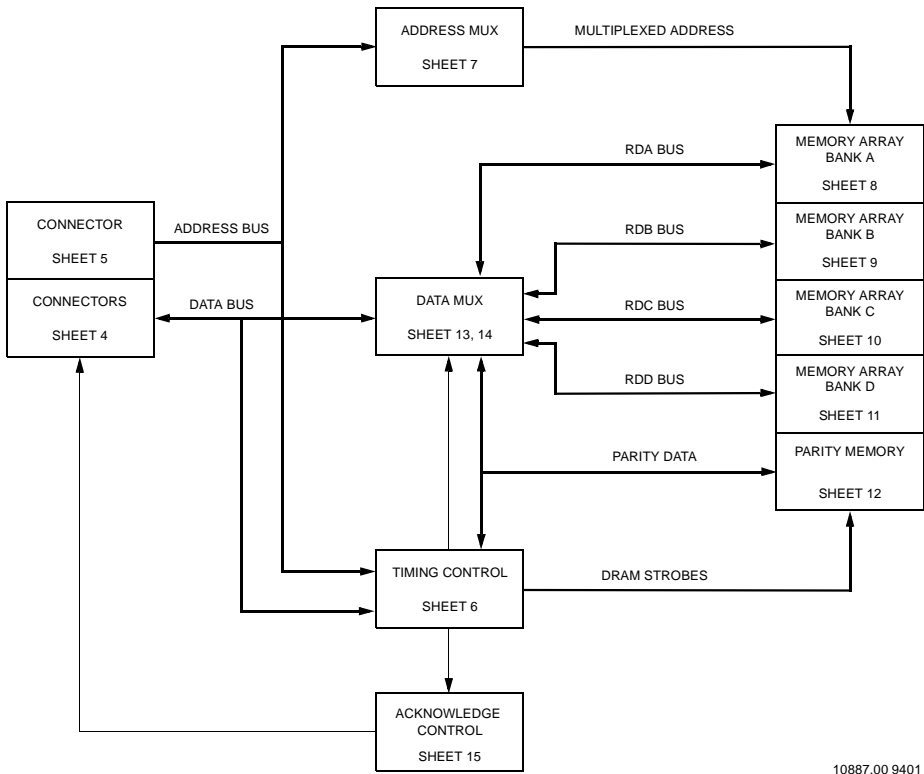

Figure 4-1. MVME167 Main Module Block Diagram



10887.00 9401

Figure 4-2. Parity DRAM Mezzanine Module Block Diagram

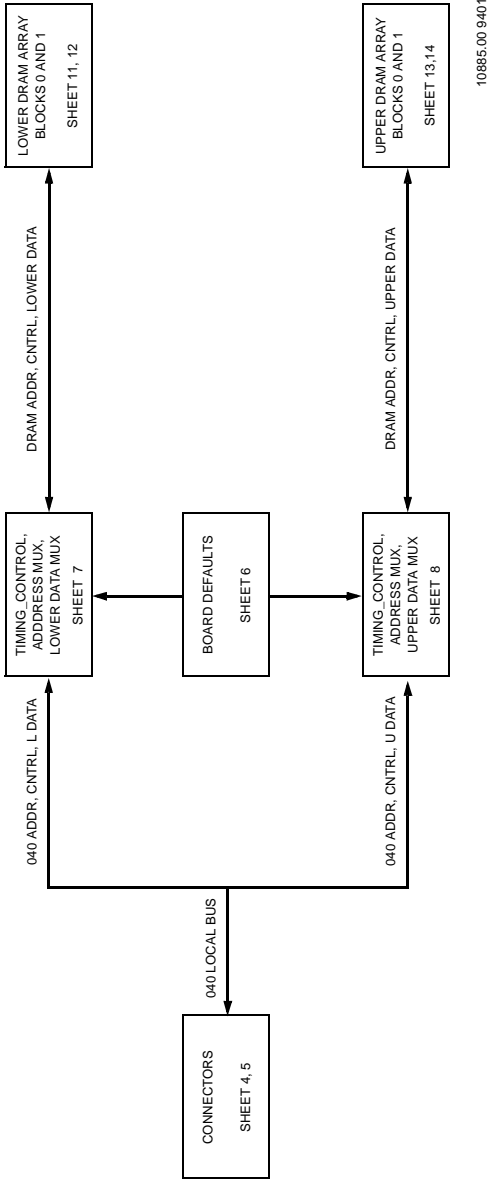

Figure 4-3. ECC DRAM Mezzanine Module Block Diagram

EIA-232-D INTERCONNECTIONS

A

Introduction

The EIA-232-D standard is the most widely used terminal/computer and terminal/modem interface, and yet it is not fully understood. This may be because not all the lines are clearly defined, and many users do not see the need to follow the standard in their applications. Many times designers think only of their own equipment, but the state of the art is computer-to-computer or computer-to-modem operation. A system should easily connect to any other.

The EIA-232-D standard was originally developed by the Bell System to connect terminals via modems. Several handshaking lines were included for that purpose. Although handshaking is unnecessary in many applications, the lines themselves remain part of many designs because they facilitate troubleshooting.

Table A-1 lists the standard EIA-232-D interconnections. To interpret this information correctly, remember that EIA-232-D was intended to connect a terminal to a modem. When computers are connected to each other without modems, one of them must be configured as a terminal (data terminal equipment: DTE) and the other as a modem (data circuit-terminating equipment: DCE). Since computers are normally configured to work with terminals, they are said to be configured as a modem in most cases.

Signal levels must lie between +3 and +15 volts for a high level, and between -3 and -15 volts for a low level. Connecting units in parallel may produce out-of-range voltages and is contrary to EIA-232-D specifications.

Table A-1. EIA-232-D Interconnections

Pin Number	Signal Mnemonic	Signal Name and Description
01		Not used.
02	TxD	TRANSMIT DATA. Data to be transmitted; input to the modem from the terminal.
03	RxD	RECEIVE DATA. Data which is demodulated from the receive line; output from the modem to the terminal.
04	RTS	REQUEST TO SEND. Input to the modem from the terminal when required to transmit a message. With RTS off, the modem carrier remains off. When RTS is turned on, the modem immediately turns on the carrier.
05	CTS	CLEAR TO SEND. Output from the modem to the terminal to indicate that message transmission can begin. When a modem is used, CTS follows the off-to-on transition of RTS after a time delay.
06	DSR	DATA SET READY. Output from the modem to the terminal to indicate that the modem is ready to transmit data.
07	SIG-GND	SIGNAL GROUND. Common return line for all signals at the modem interface.
08	DCD	DATA CARRIER DETECT. Output from the modem to the terminal to indicate that a valid carrier is being received.
09-14		Not used.
15	TxC	TRANSMIT CLOCK (DCE). Output from the modem to the terminal; clocks data from the terminal to the modem.
16		Not used.
17	RxC	RECEIVE CLOCK. Output from the modem to the terminal; clocks data from the modem to the terminal.
18, 19		Not used.
20	DTR	DATA TERMINAL READY. Input to the modem from the terminal; indicates that the terminal is ready to send or receive data.
21		Not used.
22	RI	RING INDICATOR. Output from the modem to the terminal; indicates to the terminal that an incoming call is present. The terminal causes the modem to answer the phone by carrying DTR true while RI is active.
23		Not used.
24	TxC	TRANSMIT CLOCK (DTE). Input to modem from terminal; same function as TxC on pin 15.
25	BSY	BUSY. Input to modem from terminal. A positive EIA signal applied to this pin causes the modem to go off-hook and make the associated phone busy.

NOTES: 1. A high EIA-232-D signal level is +3 to +15 volts. A low level is -3 to -15 volts. Connecting units in parallel may produce out-of-range voltages and is contrary to specifications.

2. The EIA-232-D interface is intended to connect a terminal to a modem. When computers are connected without modems, one must be configured as a modem and the other as a terminal.

Levels of Implementation

There are several levels of conformance that may be appropriate for typical EIA-232-D interconnections. The bare minimum requirement is the two data lines and a ground. The full implementation of EIA-232-D requires 12 lines; it accommodates automatic dialing, automatic answering, and synchronous transmission. A middle-of-the-road approach is illustrated in Figure A-1.

Signal Adaptations

One set of handshaking signals frequently implemented are RTS and CTS. CTS is used in many systems to inhibit transmission until the signal is high. In the modem application, RTS is turned around and returned as CTS after 150 microseconds. RTS is programmable in some systems to work with the older type 202 modem (half duplex). CTS is used in some systems to provide flow control to avoid buffer overflow. This is not possible if modems are used. It is usually necessary to make CTS high by connecting it to RTS or to some source of +12 volts such as the resistors shown in Figure A-1. CTS is also frequently jumpered to an MC1488 gate which has its inputs grounded (the gate is provided for this purpose).

Another signal used in many systems is DCD. The original purpose of this signal was to tell the system that the carrier tone from the distant modem was being received. This signal is frequently used by the software to display a message like `CARRIER NOT PRESENT` to help the user to diagnose failure to communicate. Obviously, if the system is designed properly to use this signal and is not connected to a modem, the signal must be provided by a pullup resistor or gate as described above (see Figure A-1).

Many modems expect a DTR high signal and issue a DSR. These signals are used by software to help prompt the operator about possible causes of trouble. The DTR signal is sometimes used to disconnect the phone circuit in preparation for another automatic call. It is necessary to provide these signals in order to talk to all possible modems (see Figure A-1).

Sample Configurations

Figure A-1 is a good minimum configuration that almost always works. If the CTS and DCD signals are not received from the modem, the jumpers can be moved to artificially provide the needed signal.

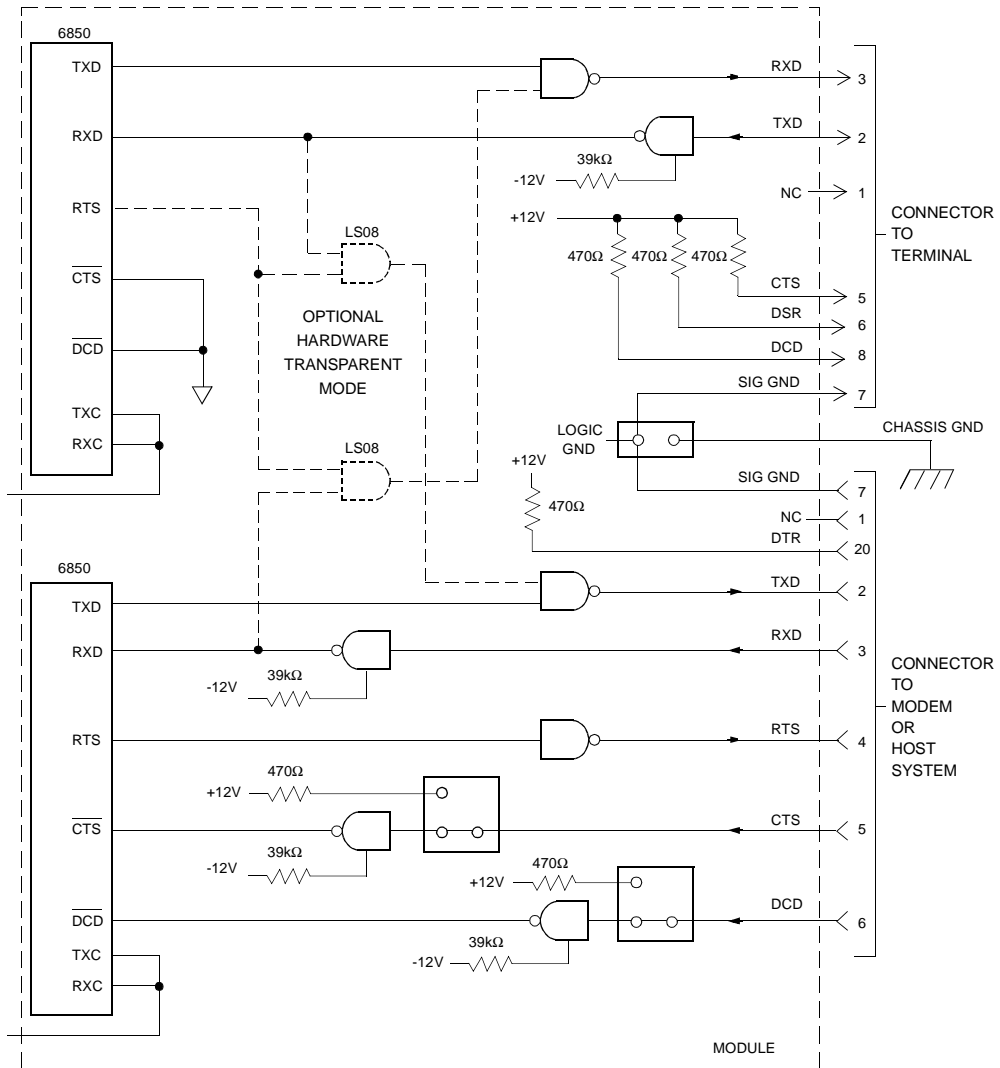

cb181 9210

Figure A-1. Middle-of-the-Road EIA-232-D Configuration

Figure A-2 shows a way of wiring an EIA-232-D connector to enable a computer to connect to a basic terminal with only three lines. This is feasible because most terminals have a DTR signal that is ON, and which can be used to pull up the CTS, DCD and DSR signals. Two of these connectors wired back-to-back can be used. In this implementation, however, diagnostic messages that might otherwise be generated do not occur because all the handshaking is bypassed. In addition, the TX and RX lines may have to be crossed since TX from a terminal is outgoing but the TX line on a modem is an incoming signal.

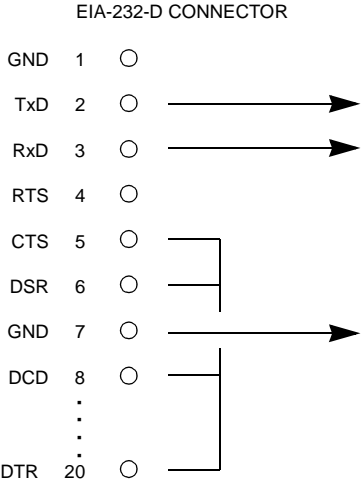

Figure A-2. Minimum EIA-232-D Connection

Proper Grounding

Another subject to consider is the use of ground pins. There are two pins labeled GND. Pin 7 is the SIGNAL GROUND and must be connected to the distant device to complete the circuit. Pin 1 is the CHASSIS GROUND, but it must be used with care. The chassis is connected to the power ground through the green wire in the power cord and must be connected to the chassis to be in compliance with the electrical code.

The problem is that when units are connected to different electrical outlets, there may be several volts of difference in ground potential. If pin 1 of each device is interconnected with the others via cable, several amperes of current could result. This condition may not only be dangerous for the small wires in a typical cable, but may also produce electrical noise that causes errors in data transmission. That is why Figure A-1 shows no connection for pin 1. Normally, pin 7 should only be connected to the CHASSIS GROUND at one point; if several terminals are used with one computer, the logical place for that point is at the computer. The terminals should not have a connection between the logic ground return and the chassis.

Index

When using this index, keep in mind that a page number indicates only where referenced material begins. It may extend to the page or pages following the page referenced.

Numerics

- 167Bug (see debug monitor and MVME167Bug) 1-6, 2-2, 2-6, 3-1, 3-30
- 53C710 (see SCSI Controller) 4-7
- 53C710 SCSI memory map 3-24
- 82596CA (see Ethernet and LAN) 4-6
- 82596CA Ethernet LAN memory map 3-23

A

- ABORT switch interrupter 3-1
- ABORT switch S1 3-1
- adapter board (see P2 adapter board) 1-5, 2-7
- ambient air temperature 1-3
- assembler/disassembler 1-6
- assertion 1-9

B

- Battery Backed Up RAM (BBRAM) and Clock (see MK48T08 and NVRAM) 4-4
- battery backup 4-2
- battery handling and disposal 4-3
- battery lifetime 4-3
- BBRAM (see Battery Backed Up RAM, MK48T08, and NVRAM) 3-26, 4-4
- BBRAM configuration area memory map 3-25
- BBRAM,TOD Clock memory map 3-26
- BG (bus grant) 2-7

- big endian mode 3-24
- binary number 1-9
- block diagram
 - ECC DRAM mezzanine module 4-13
 - MVME167 main module 4-11
 - parity DRAM mezzanine module 4-12
- board ID 3-27
- board serial number 3-27
- board speed 3-28
- bus error 3-30
- bus grant (BG) 2-7
- byte 1-9

C

- cables (see also shielded cables) 2-7
- CD2401 (see SCC and Serial Controller Chip) 4-5
- CFM (cubic feet per minute) 1-3
- chassis ground A-6
- checksum 3-28
- Cirrus Logic CD2401 serial port memory map 3-19
- conductive chassis rails 1-4
- configuration area 3-26
- controls and indicators 3-1
- cooling requirements 1-3
- CR2430 4-2
- cubic feet per minute (CFM) 1-3
- cycle times 4-8
 - local bus to DRAM 4-8
 - ROM 4-9

D

data bus structure 4-1
 data circuit-terminating equipment (DCE) A-1
 data terminal equipment (DTE) A-1
 DCE (data circuit-terminating equipment) A-1
 debug monitor (see 167Bug and MVME167Bug) 2-2, 2-6, 3-1, 3-30
 debugging package 1-7, 3-30
 decimal number 1-9
 default values
 registers 3-30
 detailed I/O memory maps 3-6
 diagnostics 1-6
 DMA 4-5, 4-6
 DRAM (dynamic RAM) 4-3
 DRAM base address 2-7
 DS1 - DS4 3-2
 DS1210S 4-2
 DTE (data terminal equipment) A-1
 dynamic RAM (DRAM) 4-3

E

ECC (error checking and correction)
 DRAM mezzanine module block diagram 4-13
 EIA-232-D 4-5
 EIA-232-D interconnections A-1, A-2
 EIA-232-D standard A-1
 EPROM sockets 1-6
 EPROM(s) 2-6, 3-4, 3-30, 4-2
 equipment required 1-6
 errata sheets, chip 3-6
 Ethernet (see 82596CA and LAN) 2-8, 4-6
 Ethernet address 3-27, 3-28
 Ethernet interface 4-6
 Ethernet station address 4-6
 Ethernet transceiver interface 4-6
 extended addressing 2-7

F

factory jumper settings 2-2
 FCC compliance 1-4
 features 1-2
 forced air cooling 1-3
 front panel 3-1
 front panel indicators (DS1- DS4) 3-2
 functional description 4-1
 fuse F1 2-8
 fuse F2 2-8

G

GCSR (Global Control and Status Registers) (see VMEchip2 GCSR) 2-8, 3-30
 GCSR board control register 3-30
 general description 1-5
 general information 1-1
 general purpose readable jumpers on header J1 2-2
 global bus timeout 2-8
 Global Control and Status Registers (GCSR) (see VMEchip2 GCSR) 2-8, 3-30
 grounding A-6

H

half duplex A-3
 handshaking A-1, A-3
 hardware interrupts
 software-programmable 4-8
 hardware preparation 2-1
 hardware preparation and installation 2-1
 hexadecimal character 1-9

I

I/O interfaces 4-5
 IACK (interrupt acknowledge) 2-7
 installation instructions 2-6
 interrupt acknowledge (IACK) 2-7
 interrupt acknowledge map 3-28

interrupts 4-8
introduction 1-1, 2-1, 3-1, 4-1, A-1

J

J1 2-2
J2 2-2
J3 4-10
J6 2-4
J7 2-4
J8 2-5
jumpers 2-1

L

LAN (see 82596CA and Ethernet) 4-6
LAN DMA transfers 4-9
LAN FIFO buffer 4-9
LAN transceiver 2-8
LCSR (Local Control and Status Registers) (see VMEchip2 LCSR) 2-2
LEDs 3-2
levels of implementation A-3
LFM (linear feet per minute) 1-3
linear feet per minute (LFM) 1-3
little endian mode 3-24
Local Area Network (see LAN) 4-6
local bus 4-8
local bus access 4-8
local bus memory map 3-3, 3-4
local bus timeout 4-8
local bus to DRAM cycle times 4-8
Local Control and Status Registers (LCSR) (see VMEchip2 LCSR) 2-2
local I/O devices memory map 3-5
local reset (LRST) 3-1, 3-30
local reset operation 3-30
local resources 4-7
local SCSI ID 3-28
location monitors 2-8
longword 1-9
LRST (local reset) 3-1, 3-30

M

manual terminology 1-9
map decoders 3-29
MC68040 MPU 4-2
MCECC 1-5
MCECC internal register memory map 3-17
MEMC040 1-5
MEMC040 internal register memory map 3-17
memory maps 3-3
53C710 SCSI 3-24
82596CA Ethernet LAN 3-23
BBRAM configuration area 3-25
BBRAM, TOD Clock 3-26
Cirrus Logic CD2401 serial port 3-19
detailed I/O 3-6
interrupt acknowledge 3-28
local bus 3-3
local I/O devices 3-5
MCECC internal register 3-17
MEMC040 internal register 3-17
MK48T08 BBRAM, TOD Clock 3-25
PCCchip2 3-14
printer 3-16
TOD clock 3-26
VMEbus 3-29
VMEbus short I/O 3-29
VMEchip2 3-8
mezzanine module
ECC DRAM 4-13
parity DRAM 4-12
middle-of-the-road EIA-232-D configuration A-4
minimum EIA-232-D connection A-5
MK48T08 (see Battery Backed Up RAM, BBRAM, and NVRAM) 4-4
MK48T08 BBRAM, TOD Clock memory map 3-25
model designations 1-1
modem(s) A-1

-
- multi-MPU programming considerations 3-30
 - MVME167 functional description 4-1
 - MVME167 main module block diagram 4-11
 - MVME167 model designations 1-1
 - MVME167 module installation 2-6
 - MVME167 specifications 1-4
 - MVME167 switches, headers, connectors, fuses, and LEDs 2-3
 - MVME167Bug (see 167Bug and debug monitor) 1-6, 2-2, 2-6, 3-1, 3-30
 - MVME167Bug debug monitor 1-6
 - MVME167Bug debugging package 1-7
 - MVME712-12 1-5
 - MVME712-13 1-5
 - MVME712A 1-5
 - MVME712AM 1-5
 - MVME712B 1-5
 - MVME712M 1-5, 2-6, 2-8
 - MVME712X 1-6, 2-6, 4-5
- N**
- negation 1-9
 - Non-Volatile RAM (NVRAM) (see Battery Backed Up RAM, BBRAM, and MK48T08) 3-26, 4-4
 - normal address range 3-3
 - NVRAM (Non-Volatile RAM) (see Battery Backed Up RAM, BBRAM, and MK48T08) 3-26, 4-4
- O**
- onboard DRAM 4-3
 - operating instructions 3-1
 - operating systems 1-6
- P**
- P2 adapter board 1-5, 2-7, 2-8
 - parallel port interface 4-6
 - parallel printer port 4-6
 - parity DRAM mezzanine module block diagram 4-12
 - PCCchip2 1-5
 - PCCchip2 memory map 3-14
 - printer interface 4-6
 - printer memory map 3-16
 - printer port 4-6
 - programmable hardware interrupts 4-8
 - programmable tick timers 4-7
 - proper grounding A-6
- R**
- registers 3-30
 - default values 3-30
 - related documentation 1-7
 - remote status and control J3 4-10
 - RESET switch S2 3-1, 3-30
 - RF emissions 1-5
 - RFI 2-7
 - ROM cycle times 4-9
 - RTXC4 (Receive Transmit Clock 4) 2-4
- S**
- S1 3-1
 - S2 3-1, 3-30
 - sample configurations A-4
 - SCC (Serial Controller Chip) (see CD2401) 4-5
 - SCSI Controller (see 53C710) 4-7
 - SCSI FIFO buffer 4-9
 - SCSI ID (see local SCSI ID) 3-28
 - SCSI interface 4-7
 - SCSI specification 1-8
 - SCSI termination 4-7
 - SCSI terminator power 2-8
 - SCSI transfers 4-9
 - Serial Controller Chip (SCC) (see CD2401) 4-5
 - serial port 4 2-4
 - serial port 4 clock configuration select headers J6 and J7 2-4
 - serial port interface 4-5

shielded cables (see also cables) 1-4, 2-7
signal adaptations A-3
signal ground A-6
signal levels A-1
signals
 transfer type (TT) 3-3
software initialization 3-30
software-programmable hardware inter-
 rupts 4-8
specifications 1-3
SRAM (static RAM) 4-2
SRAM backup power source select head-
 er J8 2-5
SRAM battery backup 4-2
SRST (system reset) 3-1, 3-30
static RAM (SRAM) 4-2
support information 1-8
SYSRESET* (see system reset) 3-1, 3-30
system considerations 2-7
system console terminal 1-6
system controller 2-2
system controller function 2-2, 3-30
system controller header J2 2-2
system mode 1-6
system reset (SRST) 3-30
system reset (SRST) (see SYSRESET*) 3-1
SYSTEM V/68 1-6
systems serial ID 3-28

T

terminal(s) A-1
terminology 1-9
tick timers 4-7
timeout 4-8
 global bus 2-8
 local bus 4-8
timers 4-7
timing performance 4-8
TOD clock memory map 3-26
transfer type (TT) signals 3-3
transition modules 1-5, 4-5
transparent mode A-4

TRXC4 (Transmit Receive Clock 4) 2-4
TT (transfer type) signals 3-3

U

unpacking instructions 2-1

V

VMEbus 3-29
VMEbus accesses to the local bus 3-29
VMEbus interface 4-4
VMEbus memory map 3-29
VMEbus short I/O memory map 3-29
VMEbus specification 1-8
VMEchip2 1-5
VMEchip2 GCSR (Global Control and
 Status Registers) 2-8
VMEchip2 LCSR (Local Control and Sta-
 tus Registers) 2-2
VMEchip2 memory map 3-8

W

warnings 4-3
watchdog timer 3-30, 4-8
word 1-9

